

		MECHANICAL ROUND: 6	
		JOB INFORMATION	
JOB DESCRIPTION: First Response Early Result 1ct Ctn - US BRAND: First Response FRONT MATERIAL #: 72029688 BACK MATERIAL #: FRONT COPY CODE #: FRFC-02014-05 BACK COPY CODE #: UPC #: 022600020141 IP #: IP102196 JOB SIZE: 1ct LAST REVISION DATE: 07/29/2024 PRINT PROCESS: Offset PRINTER: GPI, Pineville, NC PRINTER DIE #: 59124A2 SUBSTRATE: SBS Board		FRONT COLORS Cyan Magenta Yellow PANTONE 213 C PANTONE 227 C Black UV Soft Touch	
SMART ART PRODUCTION ART INFORMATION PROJECT #: 2246421 Wave_1 SKU JOB #: 2246425 CONTACT: Deb Lengyel E-MAIL: deb.lengyel@olberdingbrands.com		BACK COLORS [Color Swatches]	
Church & Dwight Co., Inc. 500 Charles Ewing Boulevard Ewing, NJ 08628 800.833.9532		NON-PRINTING COLORS Substrate Color (Front) Substrate Color (Back) Product Color	
C&D COLOR APPROVAL C&D CONTENT APPROVAL			
<small> DO NOT PLATE, ENGRAVE, OR PROCEED TO PRESS WITH THIS FILE WITHOUT PROPER INSPECTION All files and proofs must be thoroughly inspected by the recipient immediately upon receipt. It is the responsibility of the recipient to examine and proofread all files and proofs. In the event file(s) and/or proof(s) are found to be incorrect upon inspection, call 813-281-0999 and ask for the separation contact. The liability of Olberding Brand Family shall be limited to correcting and replacing the materials that we supplied that were found to be defective. Olberding Brand Family will not be liable for any other loss or damage including, but not limited to, cost of printing plates that we did not make, print cylinders, inks, substrates/printed materials, and/or make ready and press time. </small>			

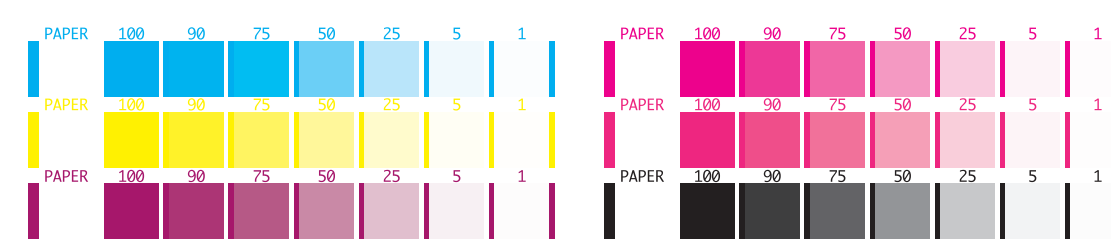

APPROVED
By Traci Downing at 4:22 pm, Aug 08, 2024

LO RES - NOT FOR PRINT

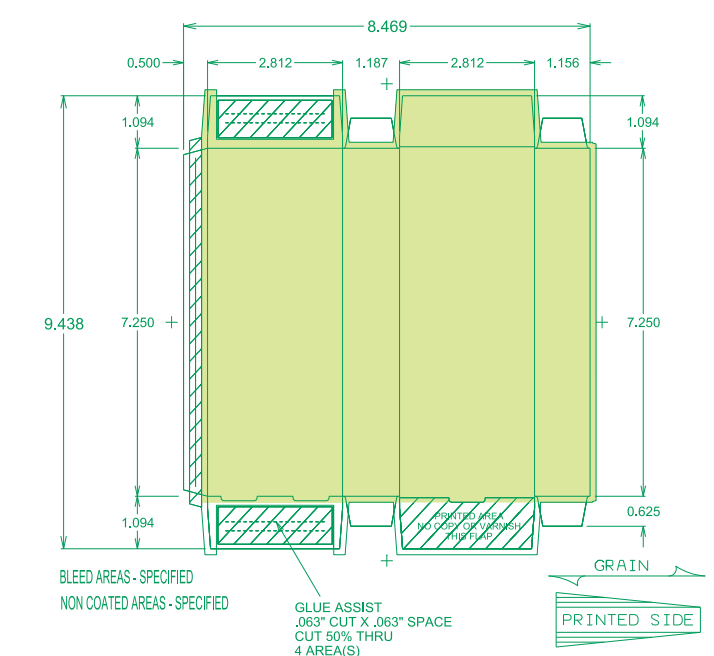

BLEED AREAS - SPECIFIED
NON COATED AREAS - SPECIFIED

GLUE ASSIST
.063" CUT X .063" SPACE
CUT 50% THRU
4 AREA(S)

GRAIN

PRINTED SIDE

SOFT TOUCH VARNISH

Olberding
BRAND FAMILY

MECHANICAL ROUND: 6

JOB INFORMATION
JOB DESCRIPTION: First Response Early Result 2ct Ctn - US

SMART ART PRODUCTION ART INFORMATION
BRAND: First Response
PROJECT #: 2246421 Wave_1
SKU JOB #: 2246428
CONTACT: Deb Lengyel
E-MAIL: deb.lengyel@olberdingbrands.com

FRONT MATERIAL #: 72029689
FRONT COPY CODE #: FRFC-90125-44
UPC #: 022600901259
JOB SIZE: 2ct
PRINT PROCESS: Offset
PRINTER: GPI, Pineville, NC
PRINTING DIE #: 59124A2
SUBSTRATE: SBS Board

BACK MATERIAL #:
BACK COPY CODE #:
IP #: IP102196
LAST REVISION DATE: 07/29/2024

C&D COLOR APPROVAL
C&D CONTENT APPROVAL

FRONT COLORS
Cyan Magenta Yellow PANTONE 213 C PANTONE 227 C Black
UV Soft Touch

BACK COLORS

NON-PRINTING COLORS
Substrate Color (Front) Substrate Color (Back) Product Color

DO NOT PLATE, ENGRAVE, OR PROCEED TO PRESS WITH THIS FILE WITHOUT PROPER INSPECTION
All files and proofs must be thoroughly inspected by the recipient immediately upon receipt. It is the responsibility of the recipient to examine and proofread all files and proofs. In the event file(s) and/or proof(s) are found to be incorrect upon inspection, call 913-281-0999 and ask for the separation contact. The liability of Olberding Brand Family shall be limited to correcting and replacing the materials that we supplied that were found to be defective. Olberding Brand Family will not be liable for any other loss or damage including, but not limited to, cost of printing plates that we did not make, print cylinders, inks, substrates/printed materials, and/or make ready and press time.

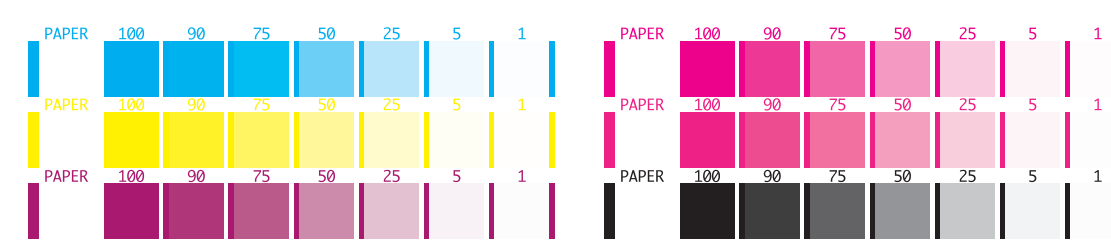

APPROVED
By Traci Downing at 4:21 pm, Aug 08, 2024

LO RES - NOT FOR PRINT

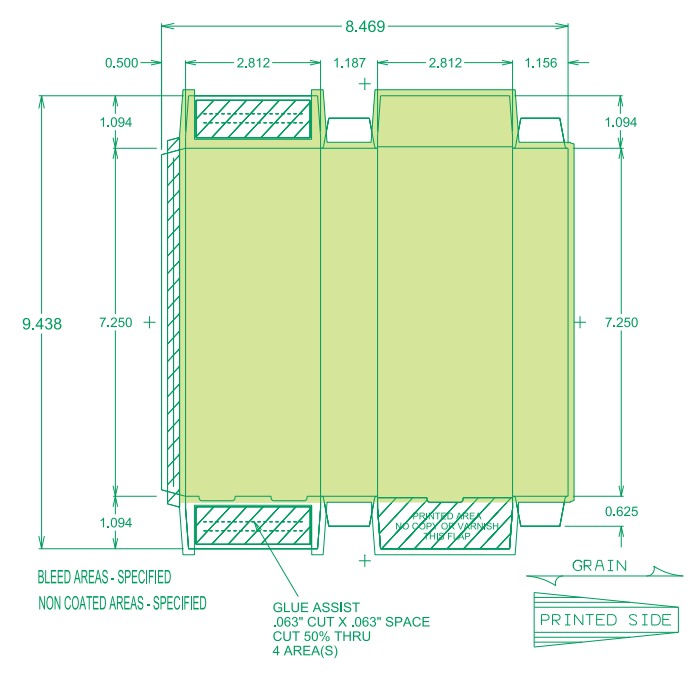

BLEED AREAS - SPECIFIED
NON COATED AREAS - SPECIFIED

GLUE ASSIST
.063" CUT X .063" SPACE
CUT 50% THRU
4 AREA(S)

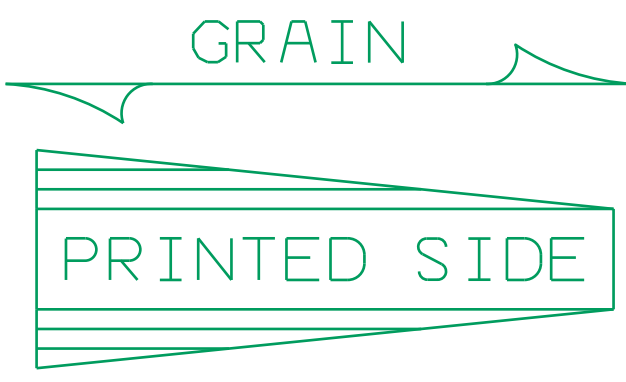

SOFT TOUCH VARNISH

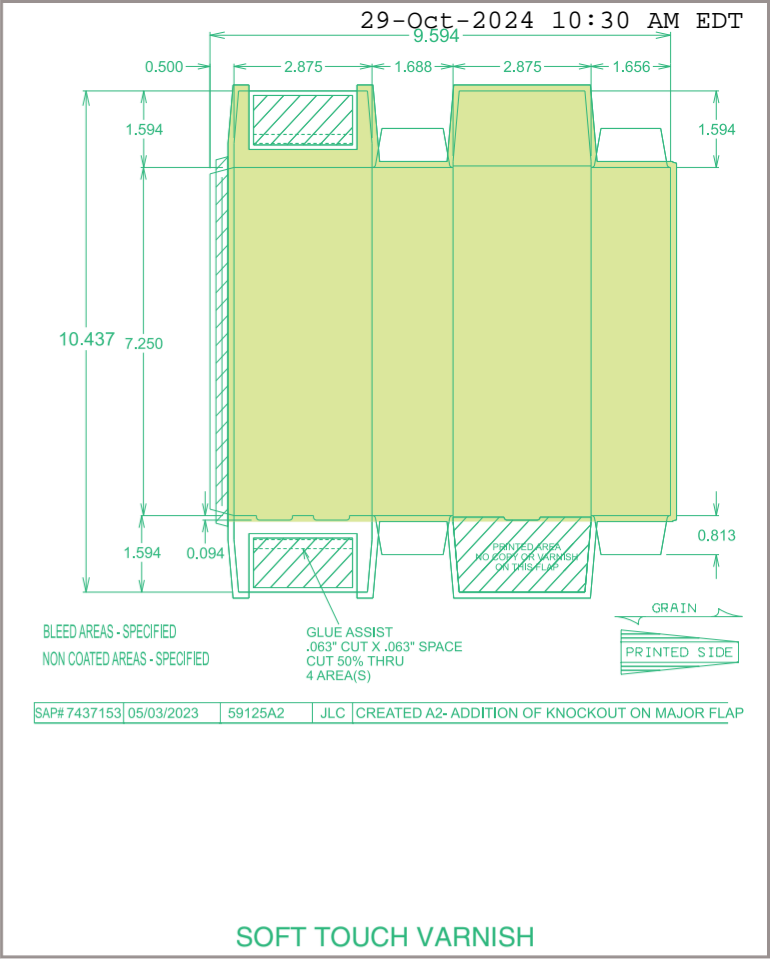
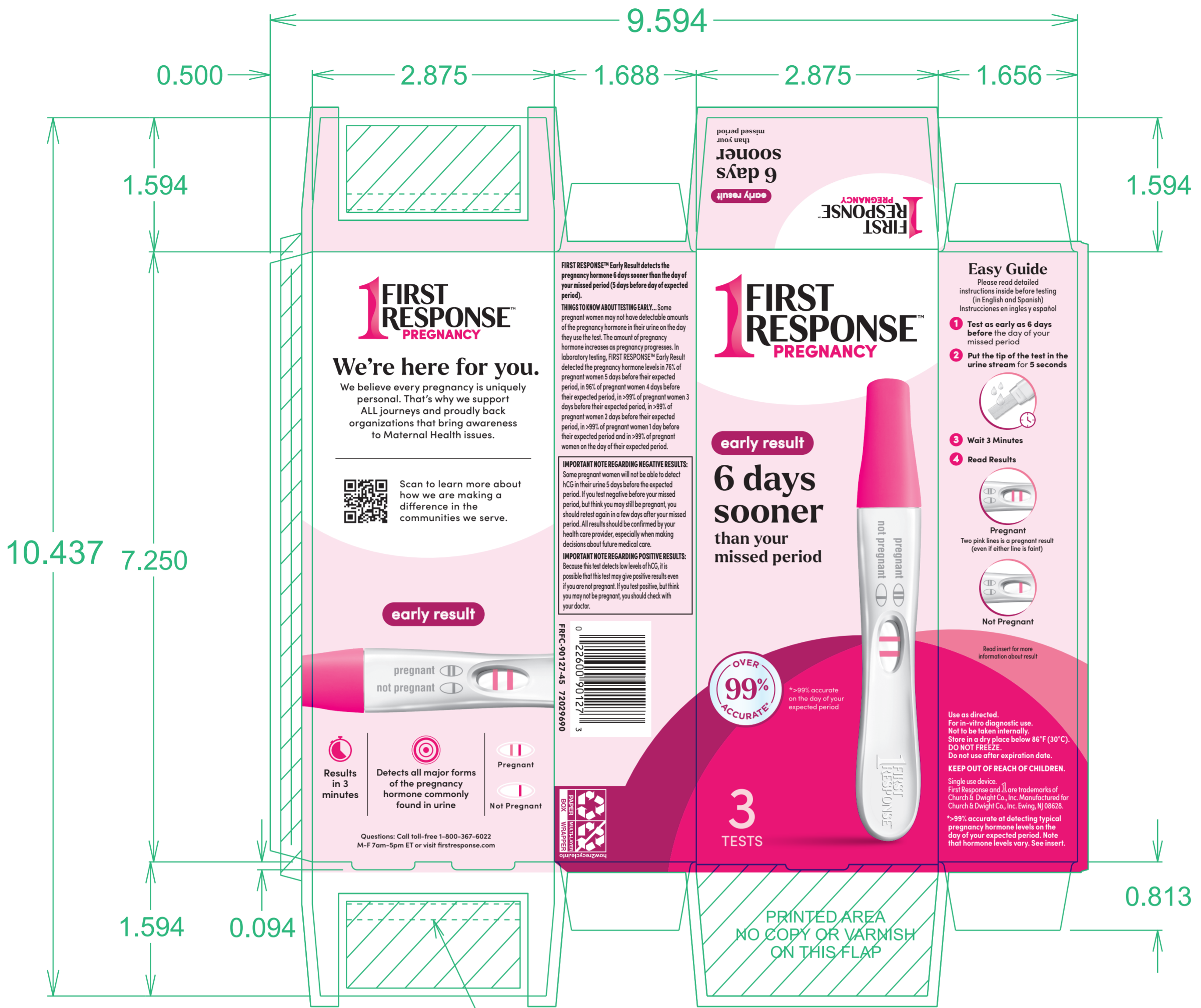

SOFT TOUCH VARNISH

BLEED AREAS - SPECIFIED
NON COATED AREAS - SPECIFIED

GLUE ASSIST
.063" CUT X .063" SPACE
CUT 50% THRU
4 AREA(S)



SAP# 7437153 05/03/2023 59125A2 JLC CREATED A2- ADDITION OF KNOCKOUT ON MAJOR FLAP

APPROVED
By Traci Downing at 4:20 pm, Aug 08, 2024

LO RES - NOT FOR PRINT

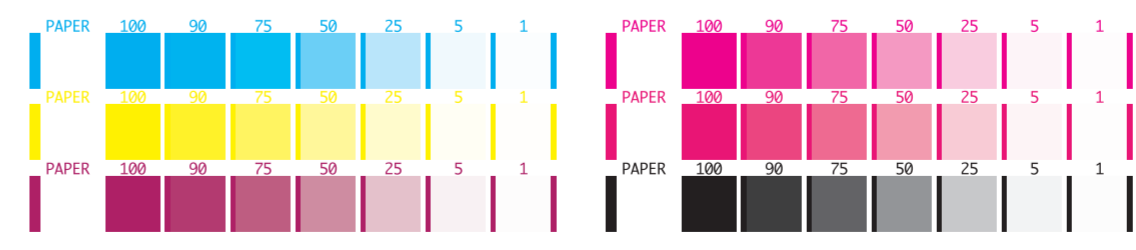

	MECHANICAL ROUND: 6	
	JOB INFORMATION JOB DESCRIPTION: First Response Early Result 3ct Ctn - US	
SMART ART PRODUCTION ART INFORMATION PROJECT #: 2246421 Wave_1 SKU JOB #: 2246429 CONTACT: Deb Lengyel E-MAIL: deb.lengyel@olberdingbrands.com	BRAND: First Response FRONT MATERIAL #: 72029690 BACK MATERIAL #: FRONT COPY CODE #: FRFC-90127-45 BACK COPY CODE #: UPC #: 022600901273 IP #: IP102197 JOB SIZE: 3ct LAST REVISION DATE: 07/29/2024 PRINT PROCESS: Offset PRINTER: GPI, Pineville, NC PRINTER DIE #: 59125A2 SUBSTRATE: SBS Board	
Church & Dwight Co., Inc. 500 Charles Ewing Boulevard Ewing, NJ 08628 800.833.9532	C&D COLOR APPROVAL C&D CONTENT APPROVAL	FRONT COLORS Cyan Magenta Yellow PANTONE 213 C PANTONE 227 C Black UV Soft Touch BACK COLORS NON-PRINTING COLORS Substrate Color (Front) Substrate Color (Back) Product Color
<p><small>DO NOT PLATE ENGRAVE. DO NOT PROCEED TO PRESS WITH THIS FILE WITHOUT PROPER INSPECTION. All files and proofs must be thoroughly inspected by the recipient immediately upon receipt. It is the responsibility of the recipient to examine and proofread all files and proofs. In the event file(s) and/or proof(s) are found to be incorrect upon inspection, call 513-281-0999 and ask for the separation contact. The liability of Olberding Brand Family shall be limited to correcting and replacing the materials that we supplied that were found to be defective. Olberding Brand Family will not be liable for any other loss or damage including, but not limited to, cost of printing plates that we did not make, print cylinders, ink, substrate/printed materials, and/or make ready and press time.</small></p>		

Safety Data Sheet

hCG Test Kit

Section 1: Identification

Product Name: hCG Test
Synonym: hCG Test Kit
CAS Number: NA
Product: hCG Test
Manufacturer/Supplier: Syntron Bioresearch, Inc.
Address: 2774 Loker Ave. West
Carlsbad, CA 92010
General Information: 760-930-2200

Section 2: Hazard(s) Identification

Potential Acute Health Effects:

Slightly hazardous in case of skin contact (irritant), of eye contact (irritant), of inhalation. Non-hazardous in case of ingestion.

Potential Chronic Health Effects:

CARCINOGENIC EFFECTS: Not available. MUTAGENIC EFFECTS: Not available. TERATOGENIC EFFECTS: Not available. DEVELOPMENTAL TOXICITY: Not available. Repeated or prolonged exposure is not known to aggravate medical condition.

Hazard description: Not classified Hazardous.

Pictogram: No hazard pictogram is used.

Signal Wording: No signal word is used.

Hazard statements: Not Applicable.

Precautionary statements: Not Applicable.

Other hazards: Not available.

Section 3: Composition/Information on Ingredients

Component	CAS Number	Weight %
Sodium azide	26628-22-8	Less than 0.02% (7.5ng/test)
(See Section 8 for Exposure Limits)		

Section 4: First-Aid Measures

Eye Contact:

Check for and remove any contact lenses. Immediately flush eyes with running water for at least 15 minutes, keeping eyelids open. Cold water may be used. Do not use an eye ointment. Seek medical attention.

Skin Contact:

After contact with skin, wash immediately with plenty of water. Gently and thoroughly wash the contaminated skin with running water and non-abrasive soap. Be particularly careful to clean folds, crevices, creases and groin. Cold water may be used. Cover the irritated skin with an emollient. If irritation persists, seek medical attention. Wash contaminated clothing before reusing.

Serious Skin Contact:

Wash with a disinfectant soap and cover the contaminated skin with an anti-bacterial cream. Seek immediate medical attention.

Inhalation:

Allow the victim to rest in a well ventilated area. Seek immediate medical attention.

Serious Inhalation:

Evacuate the victim to a safe area as soon as possible. Loosen tight clothing such as a collar, tie, belt or waistband. If breathing is difficult, administer oxygen. If the victim is not breathing, perform mouth-to-mouth resuscitation. Seek medical attention. Ingestion: Do not induce vomiting. Examine the lips and mouth to ascertain whether the tissues are damaged, a possible indication that the toxic material was ingested; the absence of such signs, however, is not conclusive. Loosen tight clothing such as a collar, tie, belt or waistband. If the victim is not breathing, perform mouth-to-mouth resuscitation. Seek immediate medical attention.

Serious Ingestion:

Not available

Section 5: Fire-Fighting Measures

Flash Point: N/A

Flammable LEL: N/A

Flammable VEL: N/A

Extinguishing Media: Use dry chemical powder.

Unusual Fire and Explosions Hazards: Contact with copper or lead drain pipes may result in the formation of potentially explosive metal azide deposits.

Section 6: Accidental Release Measures

Personal Precautions Use personal protective equipment. Ensure adequate ventilation. Avoid contact with skin, eyes and clothing.

Environmental Precautions Should not be released into the environment. See Section 12 for additional ecological information.

Methods for Containment and Clean Up Soak up with inert absorbent material. Keep in suitable, closed containers for disposal.

Section 7: Handling and Storage

Handling

Do not get in eyes, on skin or on clothing. Do not breathe vapors or mists. Keep container closed. Use only with adequate ventilation. Use good personal hygiene practices. Wash hands before eating, drinking, smoking. Remove contaminated clothing and clean before re-use. Destroy contaminated belts and shoes and other items that cannot be decontaminated. Keep away from heat and flame. Keep operating temperatures below ignition temperatures at all times. Use non-sparking tools.

Storage

Store in a cool, dry place.

The medical diagnostic kits that Syntron Bioresearch, Inc. manufactures are to be refrigerated, unless otherwise specified in the kit insert.

Section 8: Exposure Controls/Personal Protection

Engineering Controls: Provide exhaust ventilation or other engineering controls to keep the airborne concentrations of vapors below their respective threshold limit value. Ensure that eyewash stations and safety showers are proximal to the work-station location.

Personal Protection: Safety glasses. Lab coat. Vapor respirator. Be sure to use an approved/certified respirator or equivalent. Gloves.

Personal Protection in Case of a Large Spill: Splash goggles. Full suit. Vapor respirator. Boots. Gloves. A self contained

breathing apparatus should be used to avoid inhalation of the product. Suggested protective clothing might not be sufficient; consult a specialist BEFORE handling this product.

Exposure Limits: Not available.

Section 9: Physical and Chemical Properties

Melting Point/Range	No data available
Boiling Point/Range	No information available.
Flash Point	No information available.
Evaporation Rate	No information available.
Flammability (solid,gas)	No information available
Flammability or explosive limits	
Upper	No data available
Lower	No data available
Vapor Pressure	No information available.
Vapor Density	No information available.
Relative Density	No information available.
Solubility	No information available.
Partition coefficient; n-octanol/water	No data available
Autoignition Temperature	No information available.
Decomposition temperature	No information available.
Viscosity	No information available.

Section 10: Stability and Reactivity

Stability: The product is stable.

Instability Temperature: Not available.

Conditions of Instability: Excess heat, incompatible materials

Incompatibility with various substances: Acids, heavy metals (*e.g.*, lead, gold, copper, etc.), bromine, carbon disulfide, chromychloride, dibromo malonitrile, dimethyl sulfate.

Corrosivity: Not available.

Special Remarks on Reactivity: Not available.

Special Remarks on Corrosivity: Not available.

Polymerization: Will not occur.

Section 11: Toxicological Information

Acute toxicity

No data available

Inhalation: No data available

Dermal: No data available

Skin corrosion/irritation

No data available

Serious eye damage/eye irritation

No data available

Respiratory or skin sensitisation

No data available

Germ cell mutagenicity

No data available

Carcinogenicity

- IARC: No component of this product present at levels greater than or equal to 0.1% is identified as probable, possible or confirmed human carcinogen by IARC.
- ACGIH: No component of this product present at levels greater than or equal to 0.1% is identified as a carcinogen or potential carcinogen by ACGIH.
- NTP: No component of this product present at levels greater than or equal to 0.1% is identified as a known or anticipated carcinogen by NTP.
- OSHA: No component of this product present at levels greater than or equal to 0.1% is identified as a carcinogen or potential carcinogen by OSHA.

Reproductive toxicity

No data available

Specific target organ toxicity - single exposure

No data available

Specific target organ toxicity - repeated exposure

No data available

Aspiration hazard

No data available

Additional Information

Section 12: Ecological Information* (non-mandatory)

Toxicity

No data available

Persistence and degradability

No data available

Bioaccumulative potential

No data available

Mobility in soil

No data available

Results of PBT and vPvB assessment

PBT/vPvB assessment not available as chemical safety assessment not required/not conducted

Other adverse effects

No data available

Section 13: Disposal Considerations* (non-mandatory)

Waste must be disposed of in accordance with federal, state and local environmental control regulations.

Section 14: Transport Information* (non-mandatory)

DOT (US) Not dangerous goods

IMDG Not dangerous goods

IATA Not dangerous goods

Section 15: Regulatory Information* (non-mandatory)

No Data Available

Section 16: Other Information

Azide reacts with many heavy metals such as lead, copper, mercury, silver, and gold to form compounds more explosive than nitroglycerin.

The above information is believed to be correct but does not purport to be all-inclusive and shall be used only as a guide. SYNTRON BIORESEARCH, INC. shall not be held liable for any damages resulting from handling or from contact with the above products.

The statements contained herein are offered for information purposes only. We make no warranties, express or implied, and assume no liability in connection with any use of this information.

NOTE: N/A denotes information not available or non-applicable.