

Olberding BRAND FAMILY		MECHANICAL ROUND: 6	
JOB INFORMATION			
JOB DESCRIPTION: First Response Early Result 1ct Ctn - US			
BRAND: First Response			
FRONT MATERIAL #: 72029688		BACK MATERIAL #:	
FRONT COPY CODE #: FRFC-02014-05		BACK COPY CODE #:	
UPC #: 022600020141		IP #: IP102196	
JOB SIZE: 1ct		LAST REVISION DATE: 07/29/2024	
PRINT PROCESS: Offset			
PRINTER: GPI, Pineville, NC			
PRINTER DIE #: 59124A2			
SUBSTRATE: SBS Board			
C&D COLOR APPROVAL		C&D CONTENT APPROVAL	
SMART ART PRODUCTION ART INFORMATION			
PROJECT #: 2246421 Wave_1			
SKU JOB #: 2246425			
CONTACT: Deb Lengyel			
E-MAIL: deb.lengyel@olberdingbrands.com			
		Church & Dwight Co., Inc. 500 Charles Ewing Boulevard Ewing, NJ 08628 800.833.9532	
<small>DO NOT PLATE, ENGRAVE, OR PROCEED TO PRESS WITH THIS FILE WITHOUT PROPER INSPECTION</small>			
<small>All files and proofs must be thoroughly inspected by the recipient immediately upon receipt. It is the responsibility of the recipient to examine and proofread all files and proofs. In the event file(s) and/or proof(s) are found to be incorrect upon inspection, call 813-281-0999 and ask for the separation contact. The liability of Olberding Brand Family shall be limited to correcting and replacing the materials that we supplied that were found to be defective. Olberding Brand Family will not be liable for any other loss or damage including, but not limited to, cost of printing plates that we did not make, print cylinders, inks, substrates/printed materials, and/or make ready and press time.</small>			

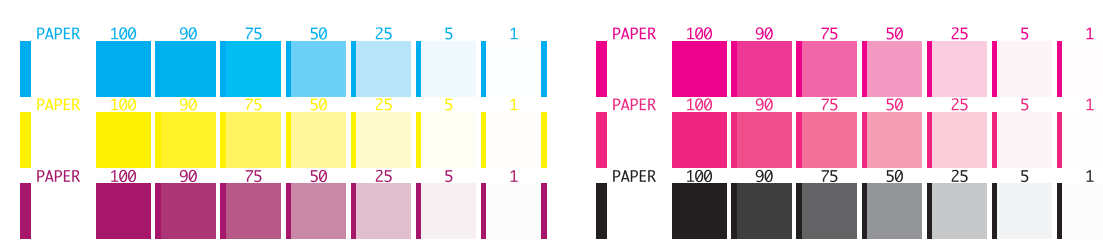

APPROVED
By Traci Downing at 4:22 pm, Aug 08, 2024

LO RES - NOT FOR PRINT

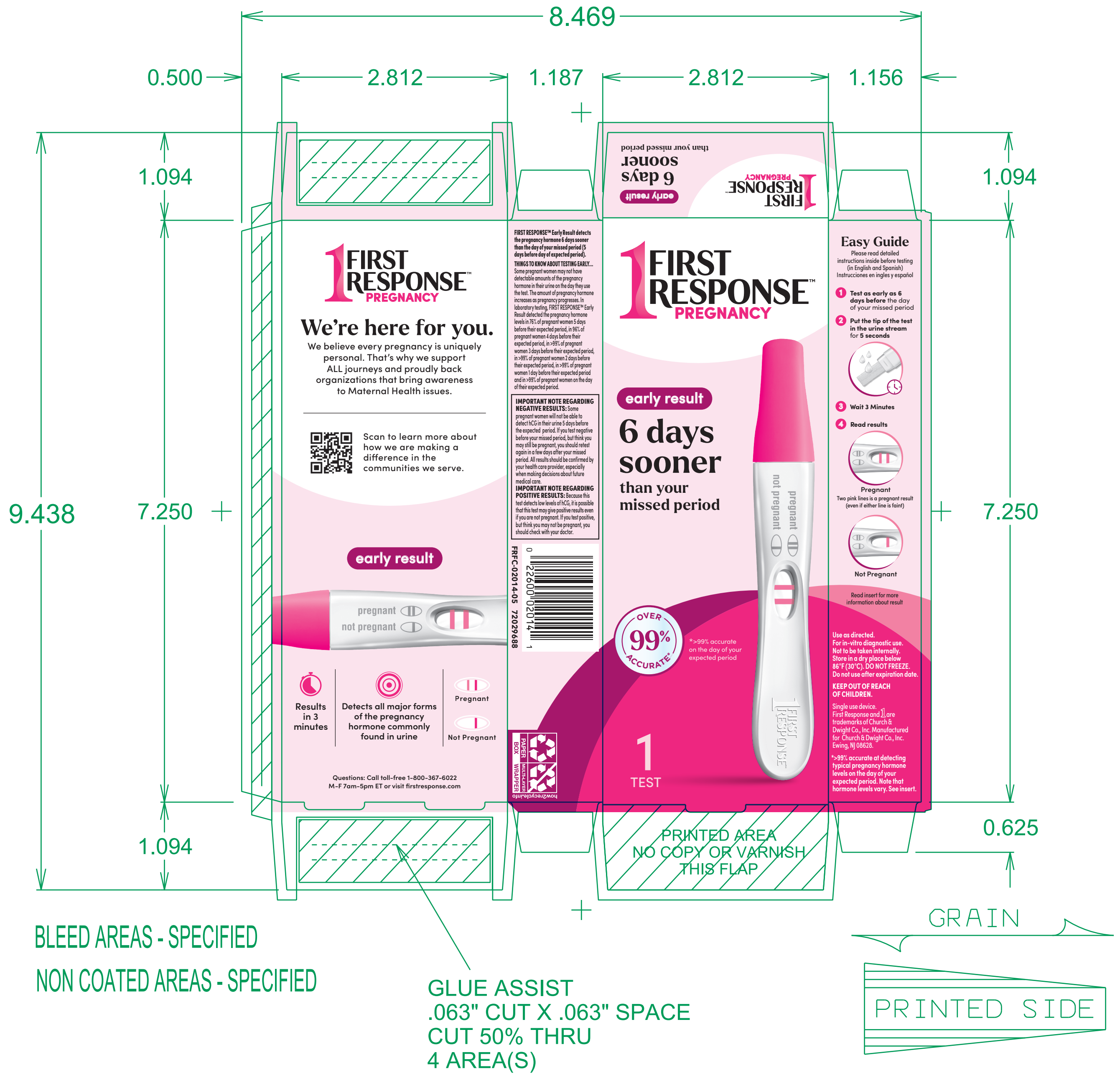
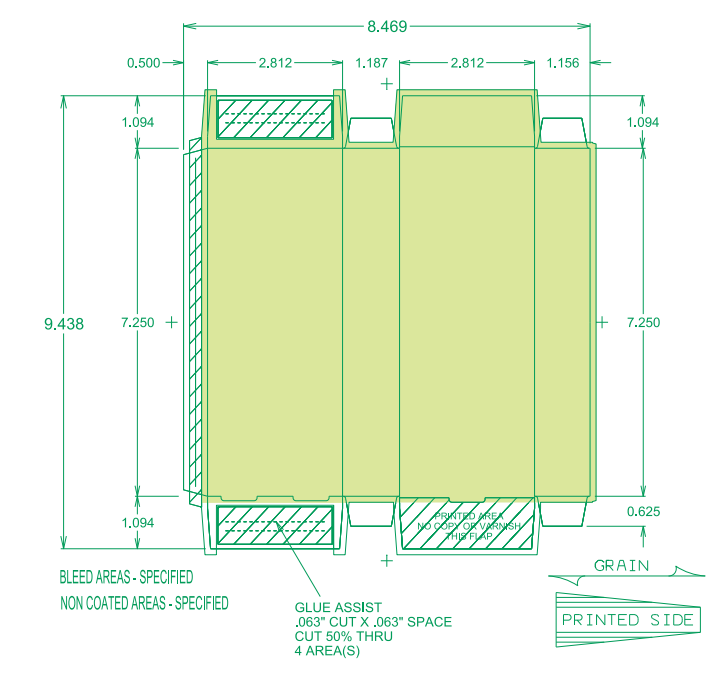

SOFT TOUCH VARNISH

Olberding
BRAND FAMILY

MECHANICAL ROUND: 6

JOB INFORMATION
JOB DESCRIPTION: First Response Early Result 2ct Ctn - US

SMART ART PRODUCTION ART INFORMATION
BRAND: First Response
PROJECT #: 2246421 Wave_1
SKU JOB #: 2246428
CONTACT: Deb Lengyel
E-MAIL: deb.lengyel@olberdingbrands.com

FRONT MATERIAL #: 72029689
FRONT COPY CODE #: FRFC-90125-44
UPC #: 022600901259
JOB SIZE: 2ct
PRINT PROCESS: Offset
PRINTER: GPI, Pineville, NC
PRINTER DIE #: 59124A2
SUBSTRATE: SBS Board

BACK MATERIAL #:
BACK COPY CODE #:
IP #: IP102196
LAST REVISION DATE: 07/29/2024

C&D COLOR APPROVAL
C&D CONTENT APPROVAL

FRONT COLORS
Cyan Magenta Yellow PANTONE 213 C PANTONE 227 C Black
UV Soft Touch

BACK COLORS

NON-PRINTING COLORS
Substrate Color (Front) Substrate Color (Back) Product Color

DO NOT PLATE, ENGRAVE, OR PROCEED TO PRESS WITH THIS FILE WITHOUT PROPER INSPECTION
All files and proofs must be thoroughly inspected by the recipient immediately upon receipt. It is the responsibility of the recipient to examine and proofread all files and proofs. In the event file(s) and/or proof(s) are found to be incorrect upon inspection, call 913-281-0999 and ask for the separation contact. The liability of Olberding Brand Family shall be limited to correcting and replacing the materials that we supplied that were found to be defective. Olberding Brand Family will not be liable for any other loss or damage including, but not limited to, cost of printing plates that we did not make, print cylinders, inks, substrates/printed materials, and/or make ready and press time.

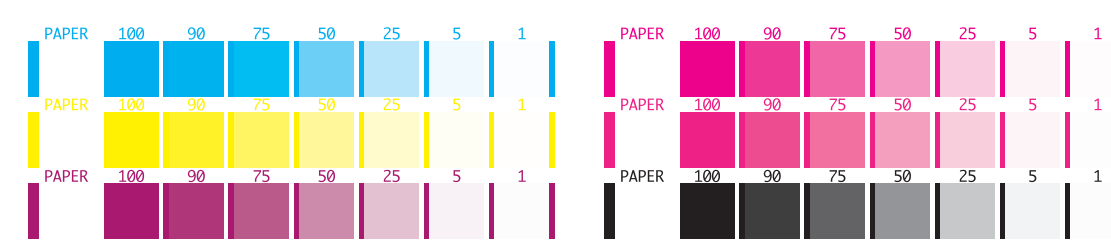

APPROVED
By Traci Downing at 4:21 pm, Aug 08, 2024

LO RES - NOT FOR PRINT

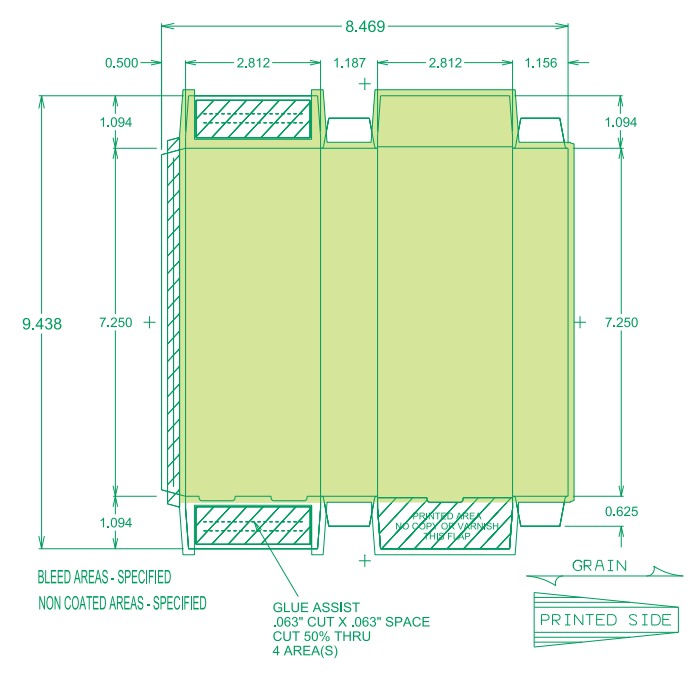

BLEED AREAS - SPECIFIED
NON COATED AREAS - SPECIFIED

GLUE ASSIST
.063" CUT X .063" SPACE
CUT 50% THRU
4 AREA(S)

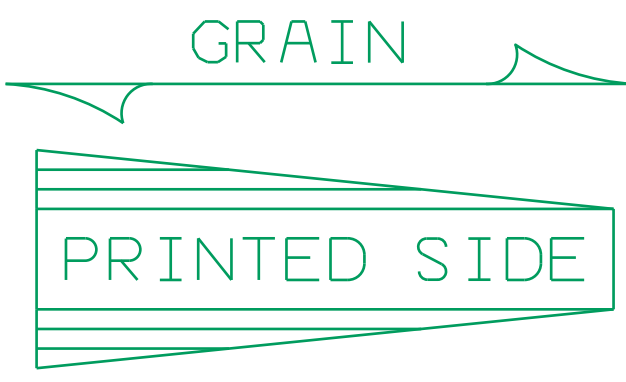

SOFT TOUCH VARNISH

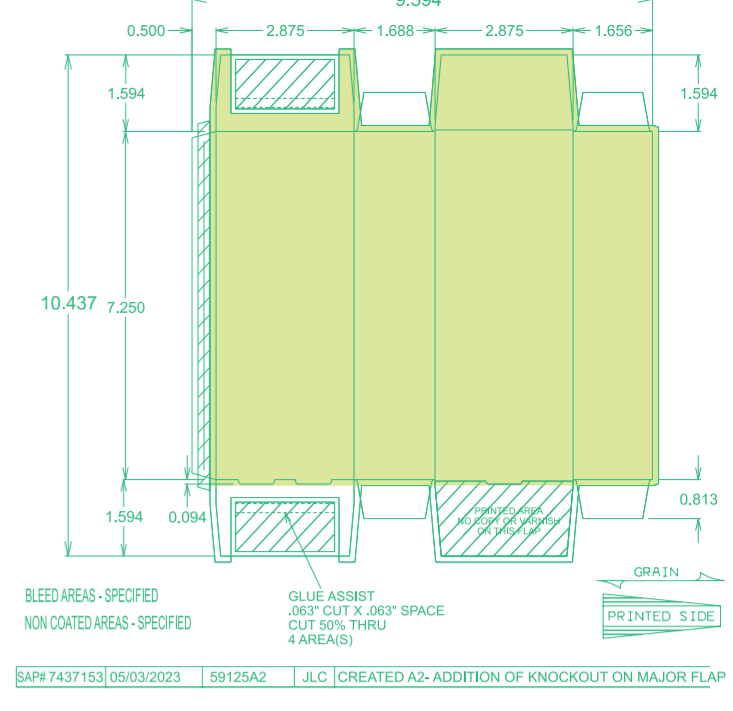
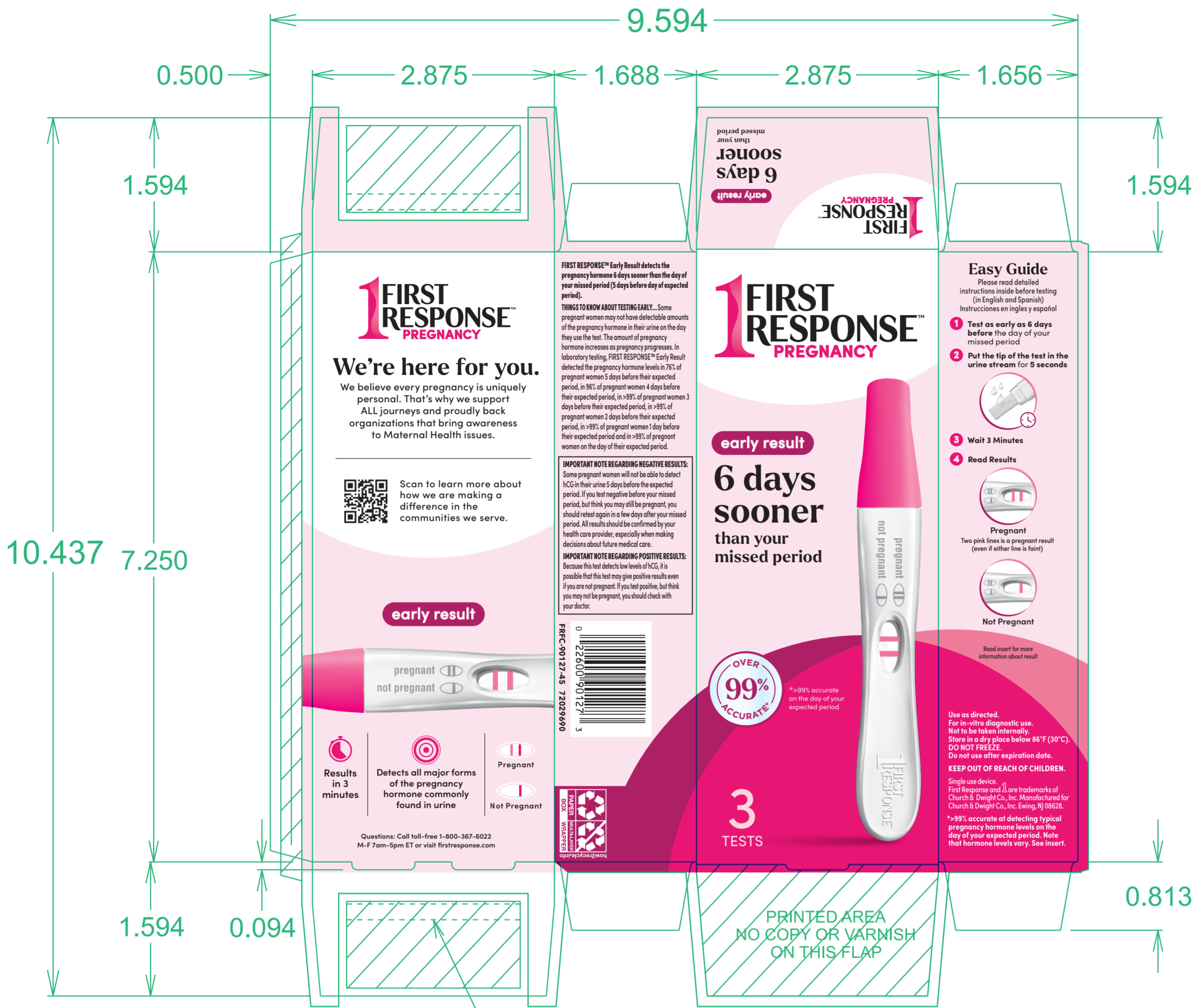

BLEED AREAS - SPECIFIED
NON COATED AREAS - SPECIFIED

GLUE ASSIST
.063" CUT X .063" SPACE
CUT 50% THRU
4 AREA(S)

SAP# 7437153 05/03/2023 59125A2 JLC CREATED A2- ADDITION OF KNOCKOUT ON MAJOR FLAP

APPROVED
By Traci Downing at 4:20 pm, Aug 08, 2024

LO RES - NOT FOR PRINT

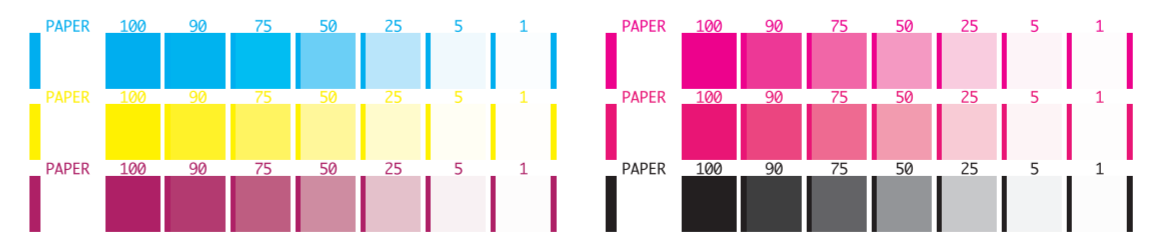

	MECHANICAL ROUND: 6		FRONT COLORS						
	JOB INFORMATION JOB DESCRIPTION: First Response Early Result 3ct Ctn - US		<input type="checkbox"/> Cyan	<input type="checkbox"/> Magenta	<input type="checkbox"/> Yellow	<input type="checkbox"/> PANTONE 211 C	<input type="checkbox"/> PANTONE 227 C	<input type="checkbox"/> Black	
SMART ART PRODUCTION ART INFORMATION PROJECT #: 2246421 Wave_1 SKU JOB #: 2246429 CONTACT: Deb Lengyel E-MAIL: deb.lengyel@olberdingbrands.com		BRAND: First Response FRONT MATERIAL #: 72029690 BACK MATERIAL #: FRONT COPY CODE #: FRFC-90127-45 BACK COPY CODE #: UPC #: 022600901273 IP #: IP102197		BACK COLORS				NON-PRINTING COLORS	
JOB SIZE: 3ct PRINT PROCESS: Offset PRINTER: GPI, Pineville, NC SUBSTRATE: SBS Board		LAST REVISION DATE: 07/29/2024		<input type="checkbox"/> UV Soft Touch				<input type="checkbox"/> Substrate Color (Front) <input type="checkbox"/> Substrate Color (Back) <input type="checkbox"/> Product Color	
C&D COLOR APPROVAL		C&D CONTENT APPROVAL		LIMITATION OF LIABILITY DO NOT PLATE, ENGRAVE, OR PROCEED TO PRESS WITH THIS FILE WITHOUT PROPER INSPECTION. All files and proofs must be thoroughly inspected by the recipient immediately upon receipt. It is the responsibility of the recipient to examine and proofread all files and proofs. In the event file(s) and/or proof(s) are found to be incorrect upon inspection, call 513-281-0999 and ask for the separation contact. The liability of Olberding Brand Family shall be limited to correcting and replacing the materials that we supplied that were found to be defective. Olberding Brand Family will not be liable for any other loss or damage including, but not limited to, cost of printing plates that we did not make, print cylinders, ink, substrate/printed materials, and/or make ready and press time.					

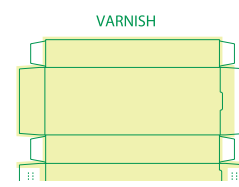
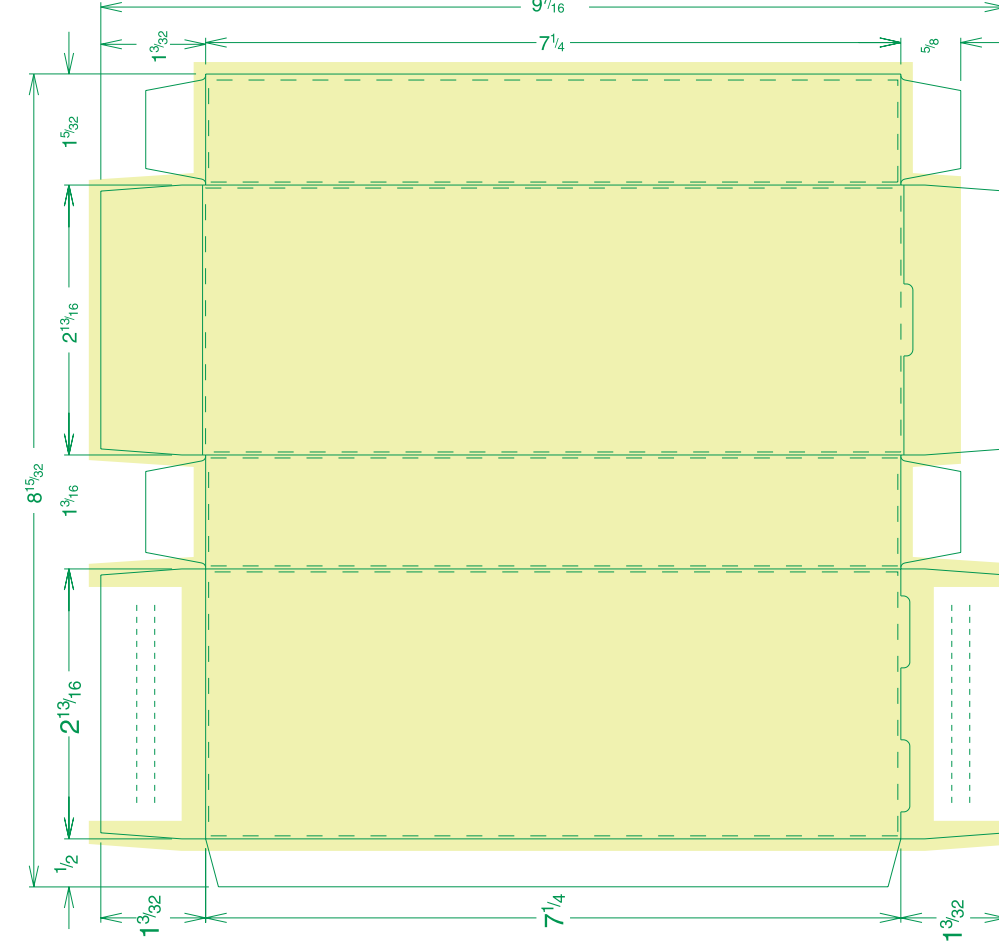

Varnish

PHOTOTYPE
SMARTart
 GRAVITY + PHOTOTYPE
 Where art and science meet.
 2141 Gilbert Ave., Cincinnati, OH 45206 513.281.0999

SMART ART PRODUCTION ART INFORMATION

PROJECT #: 1083220 Wave_1
 SKU JOB #: 1083220
 FILE NAME: PA1083220_R3.ai
 CONTACT: Kirk McCauley
 E-MAIL: mccauleyk@phototype.com

CHURCH & DWIGHT CO., INC.
 Church & Dwight Co., Inc.
 500 Charles Ewing Boulevard
 Ewing, NJ 08628
 800.833.9532

MECHANICAL: ROUND 3

JOB INFORMATION

JOB DESCRIPTION: First Response Gold Digital 2ct - US
 BRAND: PWH_FirstResponse
 FRONT MATERIAL #: notneeded BACK MATERIAL #: notneeded
 FRONT COPY CODE #: FRFC-90140-15 BACK COPY CODE #: notneeded
 UPC #: 0 22600 90140 2 LAST REVISION DATE: 11/12/2014

ADDITIONAL JOB INFORMATION (if available)

PRINT PROCESS: Offset PRINTER: Carastar Carolina Carton, Pineville, NC
 SUBSTRATE: Board PRINTER DIE#: CW11188-JB
 C&D APPROVALS
 ZPK #: 46981

FRONT COLORS

Yellow PANTONE 131 C
 Magenta PANTONE 225 C
 Cyan Black
 Varnish Dieline

BACK COLORS

QUALITY ASSURANCE CHECK

LIMITATION OF LIABILITY - DO NOT PLATE OR ENGRAVE WITH THIS FILE OR FILM WITHOUT PROPER INSPECTION

All files, film and proofs should be thoroughly inspected by the recipient immediately upon receipt. It is the responsibility of the recipient to examine and proofread all files or film prior to plating or engraving. Should the file(s) or film work be found to be incorrect upon the inspection described above, call 513.281.0999 and ask for the Contact. The liability of Phototype Engraving, Co. Inc. shall be limited to correcting & replacing its own product. Phototype Engraving, Co. Inc. will not be liable for any other loss or damage including, but not limited to, cost of printing plates, cylinders, inks, substrates and/or press time.

V011

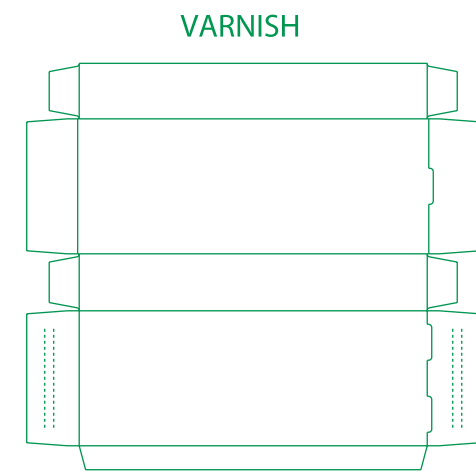
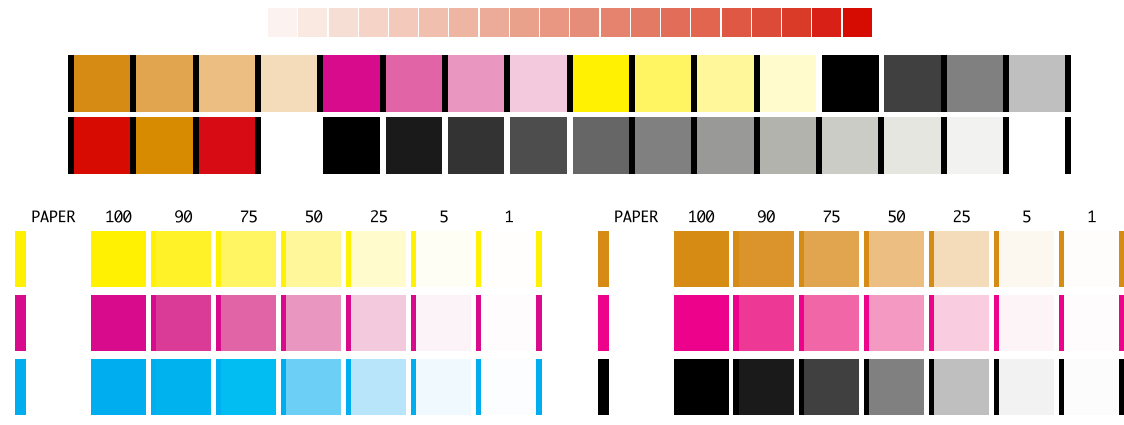

APPROVED
 By Miriam Farag at 10:42 am, Nov 24, 2014

PRODUCT SAFETY DATA SHEET**PRODUCT NAME:** Energizer Battery**Type No.:****Volts:** 3.0**TRADE NAMES:** Coin/Button Lithium Manganese Dioxide Batteries**Approximate Weight:** 0.6 – 7.0 g**CHEMICAL SYSTEM:** Lithium Manganese Dioxide**Designed for Recharge:** No

Energizer has prepared copyrighted Product Safety Datasheets to provide information on the different Eveready/Energizer battery systems. Batteries are articles as defined under the GHS and exempt from GHS classification criteria (Section 1.3.2.1.1 of the GHS). The information and recommendations set forth herein are made in good faith, for information only, and are believed to be accurate as of the date of preparation. However, ENERGIZER BATTERY MANUFACTURING, INC. MAKES NO WARRANTY, EITHER EXPRESS OR IMPLIED, WITH RESPECT TO THIS INFORMATION AND DISCLAIMS ALL LIABILITY FROM REFERENCE ON IT.

SECTION 1- MANUFACTURER INFORMATION

Manufactured for
Energizer Battery Manufacturing, Inc.
25225 Detroit Rd.
Westlake, OH 44145

Telephone Number for Information:
800-383-7323 (USA / CANADA)

Date Prepared: March 2015

SECTION 2 – HAZARDS IDENTIFICATION**GHS classification:** N/A**Signal Word:** N/A**Hazard Classification:** N/A

Under normal conditions of use, the battery is hermetically sealed.

Ingestion: Swallowing may lead to serious injury or death in as little as 2 hours due to chemical burns and potential perforation of the esophagus. **Immediately see doctor; have doctor phone (202) 625-3333.** Do not induce vomiting or give food or drink.

Inhalation: Contents of an open battery can cause respiratory irritation.

Skin Contact: Contents of an open battery can cause skin irritation.

Eye Contact: Contents of an open battery can cause severe irritation.

SECTION 3 - INGREDIENTS

IMPORTANT NOTE: The battery should not be opened or burned. Exposure to the ingredients contained within or their combustion products could be harmful.

MATERIAL OR INGREDIENT	PEL (OSHA)	TLV (ACGIH)	%/wt.
Carbon Black (CAS# 1333-86-4)	3.5 mg/m ³ TWA	3.5 mg/m ³ TWA	0-1
1,2-Dimethoxyethane (CAS# 110-71-4)	None established	None established	0-6
1,3-Dioxolane (CAS# 646-06-0)	None established	None established	0-8
Graphite (CAS# 7782-42-5)	15 mg/m ³ TWA (total dust) 5 mg/m ³ TWA (respirable fraction)	2 mg/m ³ TWA (respirable fraction)	0-3
Lithium or Lithium Alloy (CAS# 7439-93-2)	None established	None established	1-6

Lithium Perchlorate (CAS# 7791-03-9)	None established	None established	0-3
Lithium Trifluoromethanesulfonate (CAS# 33454-82-9)	None established	None established	0-3
Lithium Trifluoromethanesulfonimide (CAS# 90076-65-6)	None established	None established	0-3
Manganese Dioxide (CAS# 1313-13-9)	5 mg/m ³ Ceiling (as Mn)	0.2 mg/m ³ TWA (as Mn)	12-42
Propylene Carbonate (CAS# 108-32-7)	None established	None established	0-8
Non-Hazardous Components:			
Steel (iron CAS# 65997-19-5)	None established	None established	20
Plastic and Other	None established	None established	Balance

SECTION 4 – FIRST AID MEASURES

Ingestion: Swallowing may lead to serious injury or death in as little as 2 hours due to chemical burns and potential perforation of the esophagus. **Immediately see doctor; have doctor phone (202) 625-3333.** Do not induce vomiting or give food or drink.

Inhalation: Provide fresh air and seek medical attention.

Skin Contact: Remove contaminated clothing and wash skin with soap and water.

Eye Contact: Immediately flush eyes thoroughly with water for at least 15 minutes, lifting upper and lower lids, until no evidence of the chemical remains. Seek medical attention.

Note: Carbon black is listed as a possible carcinogen by International Agency for Research on Cancer (IARC).

SECTION 5- FIRE FIGHTING MEASURES

In case of fire where lithium batteries are present, flood area with water or smother with a Class D fire extinguishant appropriate for lithium metal, such as Lith-X. Water may not extinguish burning batteries but will cool the adjacent batteries and control the spread of fire. Burning batteries will burn themselves out. Virtually all fires involving lithium batteries can be controlled by flooding with water. However, the contents of the battery will react with water and form hydrogen gas. In a confined space, hydrogen gas can form an explosive mixture. In this situation, smothering agents are recommended. A smothering agent will extinguish burning lithium batteries.

Emergency Responders should wear self-contained breathing apparatus. Burning lithium manganese dioxide batteries produce toxic and corrosive lithium hydroxide fumes.

SECTION 6 - ACCIDENTAL RELEASE MEASURES

To cleanup leaking batteries:

Ventilation Requirements: Room ventilation may be required in areas where there are open or leaking batteries.

Respiratory Protection: Avoid exposure to electrolyte fumes from open or leaking batteries.

Eye Protection: Wear safety glasses with side shields if handling an open or leaking battery.

Gloves: Use neoprene or natural rubber gloves if handling an open or leaking battery.

Battery materials should be collected in a leak-proof container.

SECTION 7 - HANDLING AND STORAGE

Storage: Store in a cool, well ventilated area. Elevated temperatures can result in shortened battery life. In locations that handle large quantities of lithium batteries, such as warehouses, lithium batteries should be isolated from unnecessary combustibles.

Mechanical Containment: If potting or sealing the battery in an airtight or watertight container is required, consult your Energizer Battery Manufacturing, Inc. representative for precautionary suggestions. Do not obstruct safety release vents on batteries. Encapsulation of batteries will not allow cell venting and can cause high pressure rupture.

Handling: Accidental short circuit for a few seconds will not seriously affect the battery. Prolonged short circuit will cause the battery to lose energy, generate significant heat and can cause the safety release vent to open. Sources of short circuits include jumbled batteries in bulk containers, metal jewelry, metal covered tables or metal belts used for assembly of batteries into devices. Damaging a lithium battery may result in an internal short circuit.

The contents of an open battery, including a vented battery, when exposed to water, may result in a fire and/or explosion. Crushed or damaged batteries may result in a fire.

If soldering or welding to the battery is required, consult your Energizer representative for proper precautions to prevent seal damage or short circuit.

Charging: This battery is manufactured in a charged state. It is not designed for recharging. Recharging can cause battery leakage or, in some cases, high pressure rupture. Inadvertent charging can occur if a battery is installed backwards.

Labeling: If the Energizer label or package warnings are not visible, it is important to provide a package and/or device label stating:

WARNING: Battery can explode or leak and cause burns if installed backwards, disassembled, charged, or exposed to water, fire or high temperature.

Where accidental ingestion of small batteries is possible, the label should include:



(1) KEEP OUT OF REACH OF CHILDREN. Swallowing may lead to serious injury or death in as little as 2 hours due to chemical burns and potential perforation of the esophagus. **Immediately see doctor; have doctor phone (202) 625-3333.** Keep in original package until ready to use. Dispose of used batteries immediately.

SECTION 8 - EXPOSURE CONTROLS/PERSONAL PROTECTION

Ventilation Requirements: Not necessary under normal conditions.

Respiratory Protection: Not necessary under normal conditions.

Eye Protection: Not necessary under normal conditions.

Gloves: Not necessary under normal conditions.

SECTION 9 – PHYSICAL AND CHEMICAL PROPERTIES

Appearance (physical state, color, etc.):	Solid object
Upper Explosive Limits:	Not applicable for an Article
Lower Explosive Limits	Not applicable for an Article
Odor	No odor
Vapor Pressure (mm Hg @ 25°C)	Not applicable for an Article
Odor Threshold	No odor
Vapor Density (Air = 1)	Not applicable for an Article
pH	Not applicable for an Article

Density (g/cm ³)	2.0-3.0
Melting point/Freezing Point	Not applicable for an Article
Solubility in Water (% by weight)	Not applicable for an Article
Boiling Point @ 760 mm Hg (°C)	Not applicable for an Article
Flash Point	Not applicable for an Article
Evaporation Rate (Butyl Acetate = 1)	Not applicable for an Article
Flammability	Not applicable for an Article
Partition Coefficient	Not applicable for an Article
Auto-ignition Temperature	Not applicable for an Article
Decomposition Temperature	Not applicable for an Article
Viscosity	Not applicable for an Article

SECTION 10 – STABILITY AND REACTIVITY

Lithium manganese dioxide batteries contain no sulfides or cyanides and they do not meet any other reactivity criteria including “reacts violently with water” and therefore do not meet any of the criteria established in 40 CFR 261.2 for reactivity.

SECTION 11 – TOXICOLOGICAL INFORMATION

Under normal conditions of use, lithium manganese dioxide batteries are non-toxic.

SECTION 12 – ECOLOGICAL INFORMATION

Issues such as ecotoxicity, persistence and bioaccumulation are not applicable for articles.

SECTION 13 – DISPOSAL CONSIDERATIONS

Lithium iron disulfide batteries are not hazardous waste per the United States Resource Conservation and Recovery Act (RCRA) - 40 CFR Part 261 Subpart C. Dispose of in accordance with all applicable federal, state and local regulations.

SECTION 14 – TRANSPORT INFORMATION

In general, all batteries in all forms of transportation (ground, air, or ocean) must be packaged in a safe and responsible manner. Regulatory concerns from all agencies for safe packaging require that batteries be packaged in a manner that prevents short circuits and be contained in “strong outer packaging” that prevents spillage of contents. All original packaging for Energizer lithium batteries are compliant with these regulatory concerns.



Energizer lithium coin batteries are exempt from the classification as dangerous goods as they meet the requirements of the special provisions listed below. (Essentially, they are properly packaged and labeled, contain less than 1 gram of lithium and pass the tests defined in UN model regulation section 38.3).

Regulatory Body	Special Provisions
ADR	188, 230, 310, 636, 656
IMDG	188, 230, 310, 957
UN	UN 3090, UN 3091
US DOT	29, A54, A100, A101
IATA, ICAO	Packaging Instructions 968 - 970

Energizer is registered with CHEMTREC. In the event of an incident during transport call 1-800-424-9300 (North America) or 1-703-527-3887 (International).

A global lithium label chart is provided below to summarize the current global labeling requirements.

Label Summary Chart

Shipping Mode	Li content	Net quantity wt. of batteries per package	Battery Type			
AIR	0.3g to \leq 1g/cell 0.3g to \leq 2g/ battery	\leq 2.5 kg	L91, L92, L522	YES	YES	YES
	\leq 0.3g/cell	\leq 2.5kg	All Li Coin and 2L76	NO	YES	YES
	\leq 0.3g/cell	>2.5kg	All Li Coin and 2L76	YES	YES	YES
Land/ Sea only	All	All	All	NO	YES	YES

SECTION 15 - REGULATORY INFORMATION

Outside of the transportation requirements noted in Section 14, lithium manganese dioxide batteries marketed by Energizer Battery Manufacturing, Inc. are not regulated.

SARA/TITLE III - As an article, this battery and its contents are not subject to the requirements of the Emergency Planning and Community Right-To-Know Act.

SECTION 16 - OTHER INFORMATION

None.

PRODUCT SAFETY DATA SHEET

PRODUCT NAME: Energizer Battery **Type No.:** **Volts:** 3.0
TRADE NAMES: Coin/Button Lithium Manganese Dioxide Batteries **Approximate Weight:** 0.6 – 7.0 g
CHEMICAL SYSTEM: Lithium Manganese Dioxide **Designed for Recharge:** No

Energizer has prepared copyrighted Product Safety Datasheets to provide information on the different Eveready/Energizer battery systems. Batteries are articles as defined under the GHS and exempt from GHS classification criteria (Section 1.3.2.1.1 of the GHS). The information and recommendations set forth herein are made in good faith, for information only, and are believed to be accurate as of the date of preparation. However, ENERGIZER BATTERY MANUFACTURING, INC. MAKES NO WARRANTY, EITHER EXPRESS OR IMPLIED, WITH RESPECT TO THIS INFORMATION AND DISCLAIMS ALL LIABILITY FROM REFERENCE ON IT.

SECTION 1- MANUFACTURER INFORMATION

Manufactured for
Energizer Battery Manufacturing, Inc.
25225 Detroit Rd.
Westlake, OH 44145

Telephone Number for Information:
800-383-7323 (USA / CANADA)

Date Prepared: March 2015

SECTION 2 – HAZARDS IDENTIFICATION

GHS classification: N/A

Signal Word: N/A

Hazard Classification: N/A

Under normal conditions of use, the battery is hermetically sealed.

Ingestion: Swallowing may lead to serious injury or death in as little as 2 hours due to chemical burns and potential perforation of the esophagus. **Immediately see doctor; have doctor phone (202) 625-3333.** Do not induce vomiting or give food or drink.

Inhalation: Contents of an open battery can cause respiratory irritation.

Skin Contact: Contents of an open battery can cause skin irritation.

Eye Contact: Contents of an open battery can cause severe irritation.

SECTION 3 - INGREDIENTS

IMPORTANT NOTE: The battery should not be opened or burned. Exposure to the ingredients contained within or their combustion products could be harmful.

MATERIAL OR INGREDIENT	PEL (OSHA)	TLV (ACGIH)	%/wt.
Carbon Black (CAS# 1333-86-4)	3.5 mg/m ³ TWA	3.5 mg/m ³ TWA	0-1
1,2-Dimethoxyethane (CAS# 110-71-4)	None established	None established	0-6
1,3-Dioxolane (CAS# 646-06-0)	None established	None established	0-8
Graphite (CAS# 7782-42-5)	15 mg/m ³ TWA (total dust) 5 mg/m ³ TWA (respirable fraction)	2 mg/m ³ TWA (respirable fraction)	0-3
Lithium or Lithium Alloy (CAS# 7439-93-2)	None established	None established	1-6

Lithium Perchlorate (CAS# 7791-03-9)	None established	None established	0-3
Lithium Trifluoromethanesulfonate (CAS# 33454-82-9)	None established	None established	0-3
Lithium Trifluoromethanesulfonimide (CAS# 90076-65-6)	None established	None established	0-3
Manganese Dioxide (CAS# 1313-13-9)	5 mg/m ³ Ceiling (as Mn)	0.2 mg/m ³ TWA (as Mn)	12-42
Propylene Carbonate (CAS# 108-32-7)	None established	None established	0-8
Non-Hazardous Components:			
Steel (iron CAS# 65997-19-5)	None established	None established	20
Plastic and Other	None established	None established	Balance

SECTION 4 – FIRST AID MEASURES

Ingestion: Swallowing may lead to serious injury or death in as little as 2 hours due to chemical burns and potential perforation of the esophagus. **Immediately see doctor; have doctor phone (202) 625-3333.** Do not induce vomiting or give food or drink.

Inhalation: Provide fresh air and seek medical attention.

Skin Contact: Remove contaminated clothing and wash skin with soap and water.

Eye Contact: Immediately flush eyes thoroughly with water for at least 15 minutes, lifting upper and lower lids, until no evidence of the chemical remains. Seek medical attention.

Note: Carbon black is listed as a possible carcinogen by International Agency for Research on Cancer (IARC).

SECTION 5- FIRE FIGHTING MEASURES

In case of fire where lithium batteries are present, flood area with water or smother with a Class D fire extinguishant appropriate for lithium metal, such as Lith-X. Water may not extinguish burning batteries but will cool the adjacent batteries and control the spread of fire. Burning batteries will burn themselves out. Virtually all fires involving lithium batteries can be controlled by flooding with water. However, the contents of the battery will react with water and form hydrogen gas. In a confined space, hydrogen gas can form an explosive mixture. In this situation, smothering agents are recommended. A smothering agent will extinguish burning lithium batteries.

Emergency Responders should wear self-contained breathing apparatus. Burning lithium manganese dioxide batteries produce toxic and corrosive lithium hydroxide fumes.

SECTION 6 - ACCIDENTAL RELEASE MEASURES

To cleanup leaking batteries:

Ventilation Requirements: Room ventilation may be required in areas where there are open or leaking batteries.

Respiratory Protection: Avoid exposure to electrolyte fumes from open or leaking batteries.

Eye Protection: Wear safety glasses with side shields if handling an open or leaking battery.

Gloves: Use neoprene or natural rubber gloves if handling an open or leaking battery.

Battery materials should be collected in a leak-proof container.

SECTION 7 - HANDLING AND STORAGE

Storage: Store in a cool, well ventilated area. Elevated temperatures can result in shortened battery life. In locations that handle large quantities of lithium batteries, such as warehouses, lithium batteries should be isolated from unnecessary combustibles.

Mechanical Containment: If potting or sealing the battery in an airtight or watertight container is required, consult your Energizer Battery Manufacturing, Inc. representative for precautionary suggestions. Do not obstruct safety release vents on batteries. Encapsulation of batteries will not allow cell venting and can cause high pressure rupture.

Handling: Accidental short circuit for a few seconds will not seriously affect the battery. Prolonged short circuit will cause the battery to lose energy, generate significant heat and can cause the safety release vent to open. Sources of short circuits include jumbled batteries in bulk containers, metal jewelry, metal covered tables or metal belts used for assembly of batteries into devices. Damaging a lithium battery may result in an internal short circuit.

The contents of an open battery, including a vented battery, when exposed to water, may result in a fire and/or explosion. Crushed or damaged batteries may result in a fire.

If soldering or welding to the battery is required, consult your Energizer representative for proper precautions to prevent seal damage or short circuit.

Charging: This battery is manufactured in a charged state. It is not designed for recharging. Recharging can cause battery leakage or, in some cases, high pressure rupture. Inadvertent charging can occur if a battery is installed backwards.

Labeling: If the Energizer label or package warnings are not visible, it is important to provide a package and/or device label stating:

WARNING: Battery can explode or leak and cause burns if installed backwards, disassembled, charged, or exposed to water, fire or high temperature.

Where accidental ingestion of small batteries is possible, the label should include:



(1) KEEP OUT OF REACH OF CHILDREN. Swallowing may lead to serious injury or death in as little as 2 hours due to chemical burns and potential perforation of the esophagus. **Immediately see doctor; have doctor phone (202) 625-3333.** Keep in original package until ready to use. Dispose of used batteries immediately.

SECTION 8 - EXPOSURE CONTROLS/PERSONAL PROTECTION

Ventilation Requirements: Not necessary under normal conditions.

Respiratory Protection: Not necessary under normal conditions.

Eye Protection: Not necessary under normal conditions.

Gloves: Not necessary under normal conditions.

SECTION 9 – PHYSICAL AND CHEMICAL PROPERTIES

Appearance (physical state, color, etc.):	Solid object
Upper Explosive Limits:	Not applicable for an Article
Lower Explosive Limits	Not applicable for an Article
Odor	No odor
Vapor Pressure (mm Hg @ 25°C)	Not applicable for an Article
Odor Threshold	No odor
Vapor Density (Air = 1)	Not applicable for an Article
pH	Not applicable for an Article

Density (g/cm ³)	2.0-3.0
Melting point/Freezing Point	Not applicable for an Article
Solubility in Water (% by weight)	Not applicable for an Article
Boiling Point @ 760 mm Hg (°C)	Not applicable for an Article
Flash Point	Not applicable for an Article
Evaporation Rate (Butyl Acetate = 1)	Not applicable for an Article
Flammability	Not applicable for an Article
Partition Coefficient	Not applicable for an Article
Auto-ignition Temperature	Not applicable for an Article
Decomposition Temperature	Not applicable for an Article
Viscosity	Not applicable for an Article

SECTION 10 – STABILITY AND REACTIVITY

Lithium manganese dioxide batteries contain no sulfides or cyanides and they do not meet any other reactivity criteria including “reacts violently with water” and therefore do not meet any of the criteria established in 40 CFR 261.2 for reactivity.

SECTION 11 – TOXICOLOGICAL INFORMATION

Under normal conditions of use, lithium manganese dioxide batteries are non-toxic.

SECTION 12 – ECOLOGICAL INFORMATION

Issues such as ecotoxicity, persistence and bioaccumulation are not applicable for articles.

SECTION 13 – DISPOSAL CONSIDERATIONS

Lithium iron disulfide batteries are not hazardous waste per the United States Resource Conservation and Recovery Act (RCRA) - 40 CFR Part 261 Subpart C. Dispose of in accordance with all applicable federal, state and local regulations.

SECTION 14 – TRANSPORT INFORMATION

In general, all batteries in all forms of transportation (ground, air, or ocean) must be packaged in a safe and responsible manner. Regulatory concerns from all agencies for safe packaging require that batteries be packaged in a manner that prevents short circuits and be contained in “strong outer packaging” that prevents spillage of contents. All original packaging for Energizer lithium batteries are compliant with these regulatory concerns.



Energizer lithium coin batteries are exempt from the classification as dangerous goods as they meet the requirements of the special provisions listed below. (Essentially, they are properly packaged and labeled, contain less than 1 gram of lithium and pass the tests defined in UN model regulation section 38.3).

Regulatory Body	Special Provisions
ADR	188, 230, 310, 636, 656
IMDG	188, 230, 310, 957
UN	UN 3090, UN 3091
US DOT	29, A54, A100, A101
IATA, ICAO	Packaging Instructions 968 - 970

Energizer is registered with CHEMTREC. In the event of an incident during transport call 1-800-424-9300 (North America) or 1-703-527-3887 (International).

A global lithium label chart is provided below to summarize the current global labeling requirements.

Label Summary Chart

Shipping Mode	Li content	Net quantity wt. of batteries per package	Battery Type			
AIR	0.3g to \leq 1g/cell 0.3g to \leq 2g/ battery	\leq 2.5 kg	L91, L92, L522	YES	YES	YES
	\leq 0.3g/cell	\leq 2.5kg	All Li Coin and 2L76	NO	YES	YES
	\leq 0.3g/cell	>2.5kg	All Li Coin and 2L76	YES	YES	YES
Land/ Sea only	All	All	All	NO	YES	YES

SECTION 15 - REGULATORY INFORMATION

Outside of the transportation requirements noted in Section 14, lithium manganese dioxide batteries marketed by Energizer Battery Manufacturing, Inc. are not regulated.

SARA/TITLE III - As an article, this battery and its contents are not subject to the requirements of the Emergency Planning and Community Right-To-Know Act.

SECTION 16 - OTHER INFORMATION

None.

PRODUCT SAFETY DATA SHEET**PRODUCT NAME:** Energizer Battery**Type No.:****Volts:** 3.0**TRADE NAMES:** Coin/Button Lithium Manganese Dioxide Batteries**Approximate Weight:** 0.6 – 7.0 g**CHEMICAL SYSTEM:** Lithium Manganese Dioxide**Designed for Recharge:** No

Energizer has prepared copyrighted Product Safety Datasheets to provide information on the different Eveready/Energizer battery systems. Batteries are articles as defined under the GHS and exempt from GHS classification criteria (Section 1.3.2.1.1 of the GHS). The information and recommendations set forth herein are made in good faith, for information only, and are believed to be accurate as of the date of preparation. However, ENERGIZER BATTERY MANUFACTURING, INC. MAKES NO WARRANTY, EITHER EXPRESS OR IMPLIED, WITH RESPECT TO THIS INFORMATION AND DISCLAIMS ALL LIABILITY FROM REFERENCE ON IT.

SECTION 1- MANUFACTURER INFORMATION

Manufactured for
Energizer Battery Manufacturing, Inc.
25225 Detroit Rd.
Westlake, OH 44145

Telephone Number for Information:
800-383-7323 (USA / CANADA)

Date Prepared: March 2015

SECTION 2 – HAZARDS IDENTIFICATION**GHS classification:** N/A**Signal Word:** N/A**Hazard Classification:** N/A

Under normal conditions of use, the battery is hermetically sealed.

Ingestion: Swallowing may lead to serious injury or death in as little as 2 hours due to chemical burns and potential perforation of the esophagus. **Immediately see doctor; have doctor phone (202) 625-3333.** Do not induce vomiting or give food or drink.

Inhalation: Contents of an open battery can cause respiratory irritation.

Skin Contact: Contents of an open battery can cause skin irritation.

Eye Contact: Contents of an open battery can cause severe irritation.

SECTION 3 - INGREDIENTS

IMPORTANT NOTE: The battery should not be opened or burned. Exposure to the ingredients contained within or their combustion products could be harmful.

MATERIAL OR INGREDIENT	PEL (OSHA)	TLV (ACGIH)	%/wt.
Carbon Black (CAS# 1333-86-4)	3.5 mg/m ³ TWA	3.5 mg/m ³ TWA	0-1
1,2-Dimethoxyethane (CAS# 110-71-4)	None established	None established	0-6
1,3-Dioxolane (CAS# 646-06-0)	None established	None established	0-8
Graphite (CAS# 7782-42-5)	15 mg/m ³ TWA (total dust) 5 mg/m ³ TWA (respirable fraction)	2 mg/m ³ TWA (respirable fraction)	0-3
Lithium or Lithium Alloy (CAS# 7439-93-2)	None established	None established	1-6

Lithium Perchlorate (CAS# 7791-03-9)	None established	None established	0-3
Lithium Trifluoromethanesulfonate (CAS# 33454-82-9)	None established	None established	0-3
Lithium Trifluoromethanesulfonimide (CAS# 90076-65-6)	None established	None established	0-3
Manganese Dioxide (CAS# 1313-13-9)	5 mg/m ³ Ceiling (as Mn)	0.2 mg/m ³ TWA (as Mn)	12-42
Propylene Carbonate (CAS# 108-32-7)	None established	None established	0-8
Non-Hazardous Components:			
Steel (iron CAS# 65997-19-5)	None established	None established	20
Plastic and Other	None established	None established	Balance

SECTION 4 – FIRST AID MEASURES

Ingestion: Swallowing may lead to serious injury or death in as little as 2 hours due to chemical burns and potential perforation of the esophagus. **Immediately see doctor; have doctor phone (202) 625-3333.** Do not induce vomiting or give food or drink.

Inhalation: Provide fresh air and seek medical attention.

Skin Contact: Remove contaminated clothing and wash skin with soap and water.

Eye Contact: Immediately flush eyes thoroughly with water for at least 15 minutes, lifting upper and lower lids, until no evidence of the chemical remains. Seek medical attention.

Note: Carbon black is listed as a possible carcinogen by International Agency for Research on Cancer (IARC).

SECTION 5- FIRE FIGHTING MEASURES

In case of fire where lithium batteries are present, flood area with water or smother with a Class D fire extinguishant appropriate for lithium metal, such as Lith-X. Water may not extinguish burning batteries but will cool the adjacent batteries and control the spread of fire. Burning batteries will burn themselves out. Virtually all fires involving lithium batteries can be controlled by flooding with water. However, the contents of the battery will react with water and form hydrogen gas. In a confined space, hydrogen gas can form an explosive mixture. In this situation, smothering agents are recommended. A smothering agent will extinguish burning lithium batteries.

Emergency Responders should wear self-contained breathing apparatus. Burning lithium manganese dioxide batteries produce toxic and corrosive lithium hydroxide fumes.

SECTION 6 - ACCIDENTAL RELEASE MEASURES

To cleanup leaking batteries:

Ventilation Requirements: Room ventilation may be required in areas where there are open or leaking batteries.

Respiratory Protection: Avoid exposure to electrolyte fumes from open or leaking batteries.

Eye Protection: Wear safety glasses with side shields if handling an open or leaking battery.

Gloves: Use neoprene or natural rubber gloves if handling an open or leaking battery.

Battery materials should be collected in a leak-proof container.

SECTION 7 - HANDLING AND STORAGE

Storage: Store in a cool, well ventilated area. Elevated temperatures can result in shortened battery life. In locations that handle large quantities of lithium batteries, such as warehouses, lithium batteries should be isolated from unnecessary combustibles.

Mechanical Containment: If potting or sealing the battery in an airtight or watertight container is required, consult your Energizer Battery Manufacturing, Inc. representative for precautionary suggestions. Do not obstruct safety release vents on batteries. Encapsulation of batteries will not allow cell venting and can cause high pressure rupture.

Handling: Accidental short circuit for a few seconds will not seriously affect the battery. Prolonged short circuit will cause the battery to lose energy, generate significant heat and can cause the safety release vent to open. Sources of short circuits include jumbled batteries in bulk containers, metal jewelry, metal covered tables or metal belts used for assembly of batteries into devices. Damaging a lithium battery may result in an internal short circuit.

The contents of an open battery, including a vented battery, when exposed to water, may result in a fire and/or explosion. Crushed or damaged batteries may result in a fire.

If soldering or welding to the battery is required, consult your Energizer representative for proper precautions to prevent seal damage or short circuit.

Charging: This battery is manufactured in a charged state. It is not designed for recharging. Recharging can cause battery leakage or, in some cases, high pressure rupture. Inadvertent charging can occur if a battery is installed backwards.

Labeling: If the Energizer label or package warnings are not visible, it is important to provide a package and/or device label stating:

WARNING: Battery can explode or leak and cause burns if installed backwards, disassembled, charged, or exposed to water, fire or high temperature.

Where accidental ingestion of small batteries is possible, the label should include:



(1) KEEP OUT OF REACH OF CHILDREN. Swallowing may lead to serious injury or death in as little as 2 hours due to chemical burns and potential perforation of the esophagus. **Immediately see doctor; have doctor phone (202) 625-3333.** Keep in original package until ready to use. Dispose of used batteries immediately.

SECTION 8 - EXPOSURE CONTROLS/PERSONAL PROTECTION

Ventilation Requirements: Not necessary under normal conditions.

Respiratory Protection: Not necessary under normal conditions.

Eye Protection: Not necessary under normal conditions.

Gloves: Not necessary under normal conditions.

SECTION 9 – PHYSICAL AND CHEMICAL PROPERTIES

Appearance (physical state, color, etc.):	Solid object
Upper Explosive Limits:	Not applicable for an Article
Lower Explosive Limits	Not applicable for an Article
Odor	No odor
Vapor Pressure (mm Hg @ 25°C)	Not applicable for an Article
Odor Threshold	No odor
Vapor Density (Air = 1)	Not applicable for an Article
pH	Not applicable for an Article

Density (g/cm ³)	2.0-3.0
Melting point/Freezing Point	Not applicable for an Article
Solubility in Water (% by weight)	Not applicable for an Article
Boiling Point @ 760 mm Hg (°C)	Not applicable for an Article
Flash Point	Not applicable for an Article
Evaporation Rate (Butyl Acetate = 1)	Not applicable for an Article
Flammability	Not applicable for an Article
Partition Coefficient	Not applicable for an Article
Auto-ignition Temperature	Not applicable for an Article
Decomposition Temperature	Not applicable for an Article
Viscosity	Not applicable for an Article

SECTION 10 – STABILITY AND REACTIVITY

Lithium manganese dioxide batteries contain no sulfides or cyanides and they do not meet any other reactivity criteria including “reacts violently with water” and therefore do not meet any of the criteria established in 40 CFR 261.2 for reactivity.

SECTION 11 – TOXICOLOGICAL INFORMATION

Under normal conditions of use, lithium manganese dioxide batteries are non-toxic.

SECTION 12 – ECOLOGICAL INFORMATION

Issues such as ecotoxicity, persistence and bioaccumulation are not applicable for articles.

SECTION 13 – DISPOSAL CONSIDERATIONS

Lithium iron disulfide batteries are not hazardous waste per the United States Resource Conservation and Recovery Act (RCRA) - 40 CFR Part 261 Subpart C. Dispose of in accordance with all applicable federal, state and local regulations.

SECTION 14 – TRANSPORT INFORMATION

In general, all batteries in all forms of transportation (ground, air, or ocean) must be packaged in a safe and responsible manner. Regulatory concerns from all agencies for safe packaging require that batteries be packaged in a manner that prevents short circuits and be contained in “strong outer packaging” that prevents spillage of contents. All original packaging for Energizer lithium batteries are compliant with these regulatory concerns.



Energizer lithium coin batteries are exempt from the classification as dangerous goods as they meet the requirements of the special provisions listed below. (Essentially, they are properly packaged and labeled, contain less than 1 gram of lithium and pass the tests defined in UN model regulation section 38.3).

Regulatory Body	Special Provisions
ADR	188, 230, 310, 636, 656
IMDG	188, 230, 310, 957
UN	UN 3090, UN 3091
US DOT	29, A54, A100, A101
IATA, ICAO	Packaging Instructions 968 - 970

Energizer is registered with CHEMTREC. In the event of an incident during transport call 1-800-424-9300 (North America) or 1-703-527-3887 (International).

A global lithium label chart is provided below to summarize the current global labeling requirements.

Label Summary Chart

Shipping Mode	Li content	Net quantity wt. of batteries per package	Battery Type			
AIR	0.3g to ≤ 1 g/cell 0.3g to ≤ 2 g/ battery	≤ 2.5 kg	L91, L92, L522	YES	YES	YES
	≤ 0.3 g/cell	≤ 2.5 kg	All Li Coin and 2L76	NO	YES	YES
	≤ 0.3 g/cell	> 2.5 kg	All Li Coin and 2L76	YES	YES	YES
Land/ Sea only	All	All	All	NO	YES	YES

SECTION 15 - REGULATORY INFORMATION

Outside of the transportation requirements noted in Section 14, lithium manganese dioxide batteries marketed by Energizer Battery Manufacturing, Inc. are not regulated.

SARA/TITLE III - As an article, this battery and its contents are not subject to the requirements of the Emergency Planning and Community Right-To-Know Act.

SECTION 16 - OTHER INFORMATION

None.

PRODUCT SAFETY DATA SHEET

PRODUCT NAME: Energizer Battery **Type No.:** **Volts:** 3.0
TRADE NAMES: Coin/Button Lithium Manganese Dioxide Batteries **Approximate Weight:** 0.6 – 7.0 g
CHEMICAL SYSTEM: Lithium Manganese Dioxide **Designed for Recharge:** No

Energizer has prepared copyrighted Product Safety Datasheets to provide information on the different Eveready/Energizer battery systems. Batteries are articles as defined under the GHS and exempt from GHS classification criteria (Section 1.3.2.1.1 of the GHS). The information and recommendations set forth herein are made in good faith, for information only, and are believed to be accurate as of the date of preparation. However, ENERGIZER BATTERY MANUFACTURING, INC. MAKES NO WARRANTY, EITHER EXPRESS OR IMPLIED, WITH RESPECT TO THIS INFORMATION AND DISCLAIMS ALL LIABILITY FROM REFERENCE ON IT.

SECTION 1- MANUFACTURER INFORMATION

Manufactured for
Energizer Battery Manufacturing, Inc.
25225 Detroit Rd.
Westlake, OH 44145

Telephone Number for Information:
800-383-7323 (USA / CANADA)

Date Prepared: March 2015

SECTION 2 – HAZARDS IDENTIFICATION

GHS classification: N/A

Signal Word: N/A

Hazard Classification: N/A

Under normal conditions of use, the battery is hermetically sealed.

Ingestion: Swallowing may lead to serious injury or death in as little as 2 hours due to chemical burns and potential perforation of the esophagus. **Immediately see doctor; have doctor phone (202) 625-3333.** Do not induce vomiting or give food or drink.

Inhalation: Contents of an open battery can cause respiratory irritation.

Skin Contact: Contents of an open battery can cause skin irritation.

Eye Contact: Contents of an open battery can cause severe irritation.

SECTION 3 - INGREDIENTS

IMPORTANT NOTE: The battery should not be opened or burned. Exposure to the ingredients contained within or their combustion products could be harmful.

MATERIAL OR INGREDIENT	PEL (OSHA)	TLV (ACGIH)	%/wt.
Carbon Black (CAS# 1333-86-4)	3.5 mg/m ³ TWA	3.5 mg/m ³ TWA	0-1
1,2-Dimethoxyethane (CAS# 110-71-4)	None established	None established	0-6
1,3-Dioxolane (CAS# 646-06-0)	None established	None established	0-8
Graphite (CAS# 7782-42-5)	15 mg/m ³ TWA (total dust) 5 mg/m ³ TWA (respirable fraction)	2 mg/m ³ TWA (respirable fraction)	0-3
Lithium or Lithium Alloy (CAS# 7439-93-2)	None established	None established	1-6

Lithium Perchlorate (CAS# 7791-03-9)	None established	None established	0-3
Lithium Trifluoromethanesulfonate (CAS# 33454-82-9)	None established	None established	0-3
Lithium Trifluoromethanesulfonimide (CAS# 90076-65-6)	None established	None established	0-3
Manganese Dioxide (CAS# 1313-13-9)	5 mg/m ³ Ceiling (as Mn)	0.2 mg/m ³ TWA (as Mn)	12-42
Propylene Carbonate (CAS# 108-32-7)	None established	None established	0-8
Non-Hazardous Components:			
Steel (iron CAS# 65997-19-5)	None established	None established	20
Plastic and Other	None established	None established	Balance

SECTION 4 – FIRST AID MEASURES

Ingestion: Swallowing may lead to serious injury or death in as little as 2 hours due to chemical burns and potential perforation of the esophagus. **Immediately see doctor; have doctor phone (202) 625-3333.** Do not induce vomiting or give food or drink.

Inhalation: Provide fresh air and seek medical attention.

Skin Contact: Remove contaminated clothing and wash skin with soap and water.

Eye Contact: Immediately flush eyes thoroughly with water for at least 15 minutes, lifting upper and lower lids, until no evidence of the chemical remains. Seek medical attention.

Note: Carbon black is listed as a possible carcinogen by International Agency for Research on Cancer (IARC).

SECTION 5- FIRE FIGHTING MEASURES

In case of fire where lithium batteries are present, flood area with water or smother with a Class D fire extinguishant appropriate for lithium metal, such as Lith-X. Water may not extinguish burning batteries but will cool the adjacent batteries and control the spread of fire. Burning batteries will burn themselves out. Virtually all fires involving lithium batteries can be controlled by flooding with water. However, the contents of the battery will react with water and form hydrogen gas. In a confined space, hydrogen gas can form an explosive mixture. In this situation, smothering agents are recommended. A smothering agent will extinguish burning lithium batteries.

Emergency Responders should wear self-contained breathing apparatus. Burning lithium manganese dioxide batteries produce toxic and corrosive lithium hydroxide fumes.

SECTION 6 - ACCIDENTAL RELEASE MEASURES

To cleanup leaking batteries:

Ventilation Requirements: Room ventilation may be required in areas where there are open or leaking batteries.

Respiratory Protection: Avoid exposure to electrolyte fumes from open or leaking batteries.

Eye Protection: Wear safety glasses with side shields if handling an open or leaking battery.

Gloves: Use neoprene or natural rubber gloves if handling an open or leaking battery.

Battery materials should be collected in a leak-proof container.

SECTION 7 - HANDLING AND STORAGE

Storage: Store in a cool, well ventilated area. Elevated temperatures can result in shortened battery life. In locations that handle large quantities of lithium batteries, such as warehouses, lithium batteries should be isolated from unnecessary combustibles.

Mechanical Containment: If potting or sealing the battery in an airtight or watertight container is required, consult your Energizer Battery Manufacturing, Inc. representative for precautionary suggestions. Do not obstruct safety release vents on batteries. Encapsulation of batteries will not allow cell venting and can cause high pressure rupture.

Handling: Accidental short circuit for a few seconds will not seriously affect the battery. Prolonged short circuit will cause the battery to lose energy, generate significant heat and can cause the safety release vent to open. Sources of short circuits include jumbled batteries in bulk containers, metal jewelry, metal covered tables or metal belts used for assembly of batteries into devices. Damaging a lithium battery may result in an internal short circuit.

The contents of an open battery, including a vented battery, when exposed to water, may result in a fire and/or explosion. Crushed or damaged batteries may result in a fire.

If soldering or welding to the battery is required, consult your Energizer representative for proper precautions to prevent seal damage or short circuit.

Charging: This battery is manufactured in a charged state. It is not designed for recharging. Recharging can cause battery leakage or, in some cases, high pressure rupture. Inadvertent charging can occur if a battery is installed backwards.

Labeling: If the Energizer label or package warnings are not visible, it is important to provide a package and/or device label stating:

WARNING: Battery can explode or leak and cause burns if installed backwards, disassembled, charged, or exposed to water, fire or high temperature.

Where accidental ingestion of small batteries is possible, the label should include:



(1) KEEP OUT OF REACH OF CHILDREN. Swallowing may lead to serious injury or death in as little as 2 hours due to chemical burns and potential perforation of the esophagus. **Immediately see doctor; have doctor phone (202) 625-3333.** Keep in original package until ready to use. Dispose of used batteries immediately.

SECTION 8 - EXPOSURE CONTROLS/PERSONAL PROTECTION

Ventilation Requirements: Not necessary under normal conditions.

Respiratory Protection: Not necessary under normal conditions.

Eye Protection: Not necessary under normal conditions.

Gloves: Not necessary under normal conditions.

SECTION 9 – PHYSICAL AND CHEMICAL PROPERTIES

Appearance (physical state, color, etc.):	Solid object
Upper Explosive Limits:	Not applicable for an Article
Lower Explosive Limits	Not applicable for an Article
Odor	No odor
Vapor Pressure (mm Hg @ 25°C)	Not applicable for an Article
Odor Threshold	No odor
Vapor Density (Air = 1)	Not applicable for an Article
pH	Not applicable for an Article

Density (g/cm ³)	2.0-3.0
Melting point/Freezing Point	Not applicable for an Article
Solubility in Water (% by weight)	Not applicable for an Article
Boiling Point @ 760 mm Hg (°C)	Not applicable for an Article
Flash Point	Not applicable for an Article
Evaporation Rate (Butyl Acetate = 1)	Not applicable for an Article
Flammability	Not applicable for an Article
Partition Coefficient	Not applicable for an Article
Auto-ignition Temperature	Not applicable for an Article
Decomposition Temperature	Not applicable for an Article
Viscosity	Not applicable for an Article

SECTION 10 – STABILITY AND REACTIVITY

Lithium manganese dioxide batteries contain no sulfides or cyanides and they do not meet any other reactivity criteria including “reacts violently with water” and therefore do not meet any of the criteria established in 40 CFR 261.2 for reactivity.

SECTION 11 – TOXICOLOGICAL INFORMATION

Under normal conditions of use, lithium manganese dioxide batteries are non-toxic.

SECTION 12 – ECOLOGICAL INFORMATION

Issues such as ecotoxicity, persistence and bioaccumulation are not applicable for articles.

SECTION 13 – DISPOSAL CONSIDERATIONS

Lithium iron disulfide batteries are not hazardous waste per the United States Resource Conservation and Recovery Act (RCRA) - 40 CFR Part 261 Subpart C. Dispose of in accordance with all applicable federal, state and local regulations.

SECTION 14 – TRANSPORT INFORMATION

In general, all batteries in all forms of transportation (ground, air, or ocean) must be packaged in a safe and responsible manner. Regulatory concerns from all agencies for safe packaging require that batteries be packaged in a manner that prevents short circuits and be contained in “strong outer packaging” that prevents spillage of contents. All original packaging for Energizer lithium batteries are compliant with these regulatory concerns.



Energizer lithium coin batteries are exempt from the classification as dangerous goods as they meet the requirements of the special provisions listed below. (Essentially, they are properly packaged and labeled, contain less than 1 gram of lithium and pass the tests defined in UN model regulation section 38.3).

Regulatory Body	Special Provisions
ADR	188, 230, 310, 636, 656
IMDG	188, 230, 310, 957
UN	UN 3090, UN 3091
US DOT	29, A54, A100, A101
IATA, ICAO	Packaging Instructions 968 - 970

Energizer is registered with CHEMTREC. In the event of an incident during transport call 1-800-424-9300 (North America) or 1-703-527-3887 (International).

A global lithium label chart is provided below to summarize the current global labeling requirements.

Label Summary Chart

Shipping Mode	Li content	Net quantity wt. of batteries per package	Battery Type			
AIR	0.3g to \leq 1g/cell 0.3g to \leq 2g/ battery	\leq 2.5 kg	L91, L92, L522	YES	YES	YES
	\leq 0.3g/cell	\leq 2.5kg	All Li Coin and 2L76	NO	YES	YES
	\leq 0.3g/cell	>2.5kg	All Li Coin and 2L76	YES	YES	YES
Land/ Sea only	All	All	All	NO	YES	YES

SECTION 15 - REGULATORY INFORMATION

Outside of the transportation requirements noted in Section 14, lithium manganese dioxide batteries marketed by Energizer Battery Manufacturing, Inc. are not regulated.

SARA/TITLE III - As an article, this battery and its contents are not subject to the requirements of the Emergency Planning and Community Right-To-Know Act.

SECTION 16 - OTHER INFORMATION

None.

PRODUCT SAFETY DATA SHEET

PRODUCT NAME: Energizer Battery **Type No.:** **Volts:** 3.0
TRADE NAMES: Coin/Button Lithium Manganese Dioxide Batteries **Approximate Weight:** 0.6 – 7.0 g
CHEMICAL SYSTEM: Lithium Manganese Dioxide **Designed for Recharge:** No

Energizer has prepared copyrighted Product Safety Datasheets to provide information on the different Eveready/Energizer battery systems. Batteries are articles as defined under the GHS and exempt from GHS classification criteria (Section 1.3.2.1.1 of the GHS). The information and recommendations set forth herein are made in good faith, for information only, and are believed to be accurate as of the date of preparation. However, ENERGIZER BATTERY MANUFACTURING, INC. MAKES NO WARRANTY, EITHER EXPRESS OR IMPLIED, WITH RESPECT TO THIS INFORMATION AND DISCLAIMS ALL LIABILITY FROM REFERENCE ON IT.

SECTION 1- MANUFACTURER INFORMATION

Manufactured for
Energizer Battery Manufacturing, Inc.
25225 Detroit Rd.
Westlake, OH 44145

Telephone Number for Information:
800-383-7323 (USA / CANADA)

Date Prepared: March 2015

SECTION 2 – HAZARDS IDENTIFICATION

GHS classification: N/A

Signal Word: N/A

Hazard Classification: N/A

Under normal conditions of use, the battery is hermetically sealed.

Ingestion: Swallowing may lead to serious injury or death in as little as 2 hours due to chemical burns and potential perforation of the esophagus. **Immediately see doctor; have doctor phone (202) 625-3333.** Do not induce vomiting or give food or drink.

Inhalation: Contents of an open battery can cause respiratory irritation.

Skin Contact: Contents of an open battery can cause skin irritation.

Eye Contact: Contents of an open battery can cause severe irritation.

SECTION 3 - INGREDIENTS

IMPORTANT NOTE: The battery should not be opened or burned. Exposure to the ingredients contained within or their combustion products could be harmful.

MATERIAL OR INGREDIENT	PEL (OSHA)	TLV (ACGIH)	%/wt.
Carbon Black (CAS# 1333-86-4)	3.5 mg/m ³ TWA	3.5 mg/m ³ TWA	0-1
1,2-Dimethoxyethane (CAS# 110-71-4)	None established	None established	0-6
1,3-Dioxolane (CAS# 646-06-0)	None established	None established	0-8
Graphite (CAS# 7782-42-5)	15 mg/m ³ TWA (total dust) 5 mg/m ³ TWA (respirable fraction)	2 mg/m ³ TWA (respirable fraction)	0-3
Lithium or Lithium Alloy (CAS# 7439-93-2)	None established	None established	1-6

Lithium Perchlorate (CAS# 7791-03-9)	None established	None established	0-3
Lithium Trifluoromethanesulfonate (CAS# 33454-82-9)	None established	None established	0-3
Lithium Trifluoromethanesulfonimide (CAS# 90076-65-6)	None established	None established	0-3
Manganese Dioxide (CAS# 1313-13-9)	5 mg/m ³ Ceiling (as Mn)	0.2 mg/m ³ TWA (as Mn)	12-42
Propylene Carbonate (CAS# 108-32-7)	None established	None established	0-8
Non-Hazardous Components:			
Steel (iron CAS# 65997-19-5)	None established	None established	20
Plastic and Other	None established	None established	Balance

SECTION 4 – FIRST AID MEASURES

Ingestion: Swallowing may lead to serious injury or death in as little as 2 hours due to chemical burns and potential perforation of the esophagus. **Immediately see doctor; have doctor phone (202) 625-3333.** Do not induce vomiting or give food or drink.

Inhalation: Provide fresh air and seek medical attention.

Skin Contact: Remove contaminated clothing and wash skin with soap and water.

Eye Contact: Immediately flush eyes thoroughly with water for at least 15 minutes, lifting upper and lower lids, until no evidence of the chemical remains. Seek medical attention.

Note: Carbon black is listed as a possible carcinogen by International Agency for Research on Cancer (IARC).

SECTION 5- FIRE FIGHTING MEASURES

In case of fire where lithium batteries are present, flood area with water or smother with a Class D fire extinguishant appropriate for lithium metal, such as Lith-X. Water may not extinguish burning batteries but will cool the adjacent batteries and control the spread of fire. Burning batteries will burn themselves out. Virtually all fires involving lithium batteries can be controlled by flooding with water. However, the contents of the battery will react with water and form hydrogen gas. In a confined space, hydrogen gas can form an explosive mixture. In this situation, smothering agents are recommended. A smothering agent will extinguish burning lithium batteries.

Emergency Responders should wear self-contained breathing apparatus. Burning lithium manganese dioxide batteries produce toxic and corrosive lithium hydroxide fumes.

SECTION 6 - ACCIDENTAL RELEASE MEASURES

To cleanup leaking batteries:

Ventilation Requirements: Room ventilation may be required in areas where there are open or leaking batteries.

Respiratory Protection: Avoid exposure to electrolyte fumes from open or leaking batteries.

Eye Protection: Wear safety glasses with side shields if handling an open or leaking battery.

Gloves: Use neoprene or natural rubber gloves if handling an open or leaking battery.

Battery materials should be collected in a leak-proof container.

SECTION 7 - HANDLING AND STORAGE

Storage: Store in a cool, well ventilated area. Elevated temperatures can result in shortened battery life. In locations that handle large quantities of lithium batteries, such as warehouses, lithium batteries should be isolated from unnecessary combustibles.

Mechanical Containment: If potting or sealing the battery in an airtight or watertight container is required, consult your Energizer Battery Manufacturing, Inc. representative for precautionary suggestions. Do not obstruct safety release vents on batteries. Encapsulation of batteries will not allow cell venting and can cause high pressure rupture.

Handling: Accidental short circuit for a few seconds will not seriously affect the battery. Prolonged short circuit will cause the battery to lose energy, generate significant heat and can cause the safety release vent to open. Sources of short circuits include jumbled batteries in bulk containers, metal jewelry, metal covered tables or metal belts used for assembly of batteries into devices. Damaging a lithium battery may result in an internal short circuit.

The contents of an open battery, including a vented battery, when exposed to water, may result in a fire and/or explosion. Crushed or damaged batteries may result in a fire.

If soldering or welding to the battery is required, consult your Energizer representative for proper precautions to prevent seal damage or short circuit.

Charging: This battery is manufactured in a charged state. It is not designed for recharging. Recharging can cause battery leakage or, in some cases, high pressure rupture. Inadvertent charging can occur if a battery is installed backwards.

Labeling: If the Energizer label or package warnings are not visible, it is important to provide a package and/or device label stating:

WARNING: Battery can explode or leak and cause burns if installed backwards, disassembled, charged, or exposed to water, fire or high temperature.

Where accidental ingestion of small batteries is possible, the label should include:



(1) KEEP OUT OF REACH OF CHILDREN. Swallowing may lead to serious injury or death in as little as 2 hours due to chemical burns and potential perforation of the esophagus. **Immediately see doctor; have doctor phone (202) 625-3333.** Keep in original package until ready to use. Dispose of used batteries immediately.

SECTION 8 - EXPOSURE CONTROLS/PERSONAL PROTECTION

Ventilation Requirements: Not necessary under normal conditions.

Respiratory Protection: Not necessary under normal conditions.

Eye Protection: Not necessary under normal conditions.

Gloves: Not necessary under normal conditions.

SECTION 9 – PHYSICAL AND CHEMICAL PROPERTIES

Appearance (physical state, color, etc.):	Solid object
Upper Explosive Limits:	Not applicable for an Article
Lower Explosive Limits	Not applicable for an Article
Odor	No odor
Vapor Pressure (mm Hg @ 25°C)	Not applicable for an Article
Odor Threshold	No odor
Vapor Density (Air = 1)	Not applicable for an Article
pH	Not applicable for an Article

Density (g/cm ³)	2.0-3.0
Melting point/Freezing Point	Not applicable for an Article
Solubility in Water (% by weight)	Not applicable for an Article
Boiling Point @ 760 mm Hg (°C)	Not applicable for an Article
Flash Point	Not applicable for an Article
Evaporation Rate (Butyl Acetate = 1)	Not applicable for an Article
Flammability	Not applicable for an Article
Partition Coefficient	Not applicable for an Article
Auto-ignition Temperature	Not applicable for an Article
Decomposition Temperature	Not applicable for an Article
Viscosity	Not applicable for an Article

SECTION 10 – STABILITY AND REACTIVITY

Lithium manganese dioxide batteries contain no sulfides or cyanides and they do not meet any other reactivity criteria including “reacts violently with water” and therefore do not meet any of the criteria established in 40 CFR 261.2 for reactivity.

SECTION 11 – TOXICOLOGICAL INFORMATION

Under normal conditions of use, lithium manganese dioxide batteries are non-toxic.

SECTION 12 – ECOLOGICAL INFORMATION

Issues such as ecotoxicity, persistence and bioaccumulation are not applicable for articles.

SECTION 13 – DISPOSAL CONSIDERATIONS

Lithium iron disulfide batteries are not hazardous waste per the United States Resource Conservation and Recovery Act (RCRA) - 40 CFR Part 261 Subpart C. Dispose of in accordance with all applicable federal, state and local regulations.

SECTION 14 – TRANSPORT INFORMATION

In general, all batteries in all forms of transportation (ground, air, or ocean) must be packaged in a safe and responsible manner. Regulatory concerns from all agencies for safe packaging require that batteries be packaged in a manner that prevents short circuits and be contained in “strong outer packaging” that prevents spillage of contents. All original packaging for Energizer lithium batteries are compliant with these regulatory concerns.



Energizer lithium coin batteries are exempt from the classification as dangerous goods as they meet the requirements of the special provisions listed below. (Essentially, they are properly packaged and labeled, contain less than 1 gram of lithium and pass the tests defined in UN model regulation section 38.3).

Regulatory Body	Special Provisions
ADR	188, 230, 310, 636, 656
IMDG	188, 230, 310, 957
UN	UN 3090, UN 3091
US DOT	29, A54, A100, A101
IATA, ICAO	Packaging Instructions 968 - 970

Energizer is registered with CHEMTREC. In the event of an incident during transport call 1-800-424-9300 (North America) or 1-703-527-3887 (International).

A global lithium label chart is provided below to summarize the current global labeling requirements.

Label Summary Chart

Shipping Mode	Li content	Net quantity wt. of batteries per package	Battery Type			
AIR	0.3g to ≤ 1 g/cell 0.3g to ≤ 2 g/ battery	≤ 2.5 kg	L91, L92, L522	YES	YES	YES
	≤ 0.3 g/cell	≤ 2.5 kg	All Li Coin and 2L76	NO	YES	YES
	≤ 0.3 g/cell	> 2.5 kg	All Li Coin and 2L76	YES	YES	YES
Land/ Sea only	All	All	All	NO	YES	YES

SECTION 15 - REGULATORY INFORMATION

Outside of the transportation requirements noted in Section 14, lithium manganese dioxide batteries marketed by Energizer Battery Manufacturing, Inc. are not regulated.

SARA/TITLE III - As an article, this battery and its contents are not subject to the requirements of the Emergency Planning and Community Right-To-Know Act.

SECTION 16 - OTHER INFORMATION

None.

PRODUCT SAFETY DATA SHEET**PRODUCT NAME:** Energizer Battery**Type No.:****Volts:** 3.0**TRADE NAMES:** Coin/Button Lithium Manganese Dioxide Batteries**Approximate Weight:** 0.6 – 7.0 g**CHEMICAL SYSTEM:** Lithium Manganese Dioxide**Designed for Recharge:** No

Energizer has prepared copyrighted Product Safety Datasheets to provide information on the different Eveready/Energizer battery systems. Batteries are articles as defined under the GHS and exempt from GHS classification criteria (Section 1.3.2.1.1 of the GHS). The information and recommendations set forth herein are made in good faith, for information only, and are believed to be accurate as of the date of preparation. However, ENERGIZER BATTERY MANUFACTURING, INC. MAKES NO WARRANTY, EITHER EXPRESS OR IMPLIED, WITH RESPECT TO THIS INFORMATION AND DISCLAIMS ALL LIABILITY FROM REFERENCE ON IT.

SECTION 1- MANUFACTURER INFORMATION

Manufactured for
Energizer Battery Manufacturing, Inc.
25225 Detroit Rd.
Westlake, OH 44145

Telephone Number for Information:
800-383-7323 (USA / CANADA)

Date Prepared: March 2015

SECTION 2 – HAZARDS IDENTIFICATION**GHS classification:** N/A**Signal Word:** N/A**Hazard Classification:** N/A

Under normal conditions of use, the battery is hermetically sealed.

Ingestion: Swallowing may lead to serious injury or death in as little as 2 hours due to chemical burns and potential perforation of the esophagus. **Immediately see doctor; have doctor phone (202) 625-3333.** Do not induce vomiting or give food or drink.

Inhalation: Contents of an open battery can cause respiratory irritation.

Skin Contact: Contents of an open battery can cause skin irritation.

Eye Contact: Contents of an open battery can cause severe irritation.

SECTION 3 - INGREDIENTS

IMPORTANT NOTE: The battery should not be opened or burned. Exposure to the ingredients contained within or their combustion products could be harmful.

MATERIAL OR INGREDIENT	PEL (OSHA)	TLV (ACGIH)	%/wt.
Carbon Black (CAS# 1333-86-4)	3.5 mg/m ³ TWA	3.5 mg/m ³ TWA	0-1
1,2-Dimethoxyethane (CAS# 110-71-4)	None established	None established	0-6
1,3-Dioxolane (CAS# 646-06-0)	None established	None established	0-8
Graphite (CAS# 7782-42-5)	15 mg/m ³ TWA (total dust) 5 mg/m ³ TWA (respirable fraction)	2 mg/m ³ TWA (respirable fraction)	0-3
Lithium or Lithium Alloy (CAS# 7439-93-2)	None established	None established	1-6

Lithium Perchlorate (CAS# 7791-03-9)	None established	None established	0-3
Lithium Trifluoromethanesulfonate (CAS# 33454-82-9)	None established	None established	0-3
Lithium Trifluoromethanesulfonimide (CAS# 90076-65-6)	None established	None established	0-3
Manganese Dioxide (CAS# 1313-13-9)	5 mg/m ³ Ceiling (as Mn)	0.2 mg/m ³ TWA (as Mn)	12-42
Propylene Carbonate (CAS# 108-32-7)	None established	None established	0-8
Non-Hazardous Components:			
Steel (iron CAS# 65997-19-5)	None established	None established	20
Plastic and Other	None established	None established	Balance

SECTION 4 – FIRST AID MEASURES

Ingestion: Swallowing may lead to serious injury or death in as little as 2 hours due to chemical burns and potential perforation of the esophagus. **Immediately see doctor; have doctor phone (202) 625-3333.** Do not induce vomiting or give food or drink.

Inhalation: Provide fresh air and seek medical attention.

Skin Contact: Remove contaminated clothing and wash skin with soap and water.

Eye Contact: Immediately flush eyes thoroughly with water for at least 15 minutes, lifting upper and lower lids, until no evidence of the chemical remains. Seek medical attention.

Note: Carbon black is listed as a possible carcinogen by International Agency for Research on Cancer (IARC).

SECTION 5- FIRE FIGHTING MEASURES

In case of fire where lithium batteries are present, flood area with water or smother with a Class D fire extinguishant appropriate for lithium metal, such as Lith-X. Water may not extinguish burning batteries but will cool the adjacent batteries and control the spread of fire. Burning batteries will burn themselves out. Virtually all fires involving lithium batteries can be controlled by flooding with water. However, the contents of the battery will react with water and form hydrogen gas. In a confined space, hydrogen gas can form an explosive mixture. In this situation, smothering agents are recommended. A smothering agent will extinguish burning lithium batteries.

Emergency Responders should wear self-contained breathing apparatus. Burning lithium manganese dioxide batteries produce toxic and corrosive lithium hydroxide fumes.

SECTION 6 - ACCIDENTAL RELEASE MEASURES

To cleanup leaking batteries:

Ventilation Requirements: Room ventilation may be required in areas where there are open or leaking batteries.

Respiratory Protection: Avoid exposure to electrolyte fumes from open or leaking batteries.

Eye Protection: Wear safety glasses with side shields if handling an open or leaking battery.

Gloves: Use neoprene or natural rubber gloves if handling an open or leaking battery.

Battery materials should be collected in a leak-proof container.

SECTION 7 - HANDLING AND STORAGE

Storage: Store in a cool, well ventilated area. Elevated temperatures can result in shortened battery life. In locations that handle large quantities of lithium batteries, such as warehouses, lithium batteries should be isolated from unnecessary combustibles.

Mechanical Containment: If potting or sealing the battery in an airtight or watertight container is required, consult your Energizer Battery Manufacturing, Inc. representative for precautionary suggestions. Do not obstruct safety release vents on batteries. Encapsulation of batteries will not allow cell venting and can cause high pressure rupture.

Handling: Accidental short circuit for a few seconds will not seriously affect the battery. Prolonged short circuit will cause the battery to lose energy, generate significant heat and can cause the safety release vent to open. Sources of short circuits include jumbled batteries in bulk containers, metal jewelry, metal covered tables or metal belts used for assembly of batteries into devices. Damaging a lithium battery may result in an internal short circuit.

The contents of an open battery, including a vented battery, when exposed to water, may result in a fire and/or explosion. Crushed or damaged batteries may result in a fire.

If soldering or welding to the battery is required, consult your Energizer representative for proper precautions to prevent seal damage or short circuit.

Charging: This battery is manufactured in a charged state. It is not designed for recharging. Recharging can cause battery leakage or, in some cases, high pressure rupture. Inadvertent charging can occur if a battery is installed backwards.

Labeling: If the Energizer label or package warnings are not visible, it is important to provide a package and/or device label stating:

WARNING: Battery can explode or leak and cause burns if installed backwards, disassembled, charged, or exposed to water, fire or high temperature.

Where accidental ingestion of small batteries is possible, the label should include:



(1) KEEP OUT OF REACH OF CHILDREN. Swallowing may lead to serious injury or death in as little as 2 hours due to chemical burns and potential perforation of the esophagus. **Immediately see doctor; have doctor phone (202) 625-3333.** Keep in original package until ready to use. Dispose of used batteries immediately.

SECTION 8 - EXPOSURE CONTROLS/PERSONAL PROTECTION

Ventilation Requirements: Not necessary under normal conditions.

Respiratory Protection: Not necessary under normal conditions.

Eye Protection: Not necessary under normal conditions.

Gloves: Not necessary under normal conditions.

SECTION 9 – PHYSICAL AND CHEMICAL PROPERTIES

Appearance (physical state, color, etc.):	Solid object
Upper Explosive Limits:	Not applicable for an Article
Lower Explosive Limits	Not applicable for an Article
Odor	No odor
Vapor Pressure (mm Hg @ 25°C)	Not applicable for an Article
Odor Threshold	No odor
Vapor Density (Air = 1)	Not applicable for an Article
pH	Not applicable for an Article

Density (g/cm ³)	2.0-3.0
Melting point/Freezing Point	Not applicable for an Article
Solubility in Water (% by weight)	Not applicable for an Article
Boiling Point @ 760 mm Hg (°C)	Not applicable for an Article
Flash Point	Not applicable for an Article
Evaporation Rate (Butyl Acetate = 1)	Not applicable for an Article
Flammability	Not applicable for an Article
Partition Coefficient	Not applicable for an Article
Auto-ignition Temperature	Not applicable for an Article
Decomposition Temperature	Not applicable for an Article
Viscosity	Not applicable for an Article

SECTION 10 – STABILITY AND REACTIVITY

Lithium manganese dioxide batteries contain no sulfides or cyanides and they do not meet any other reactivity criteria including “reacts violently with water” and therefore do not meet any of the criteria established in 40 CFR 261.2 for reactivity.

SECTION 11 – TOXICOLOGICAL INFORMATION

Under normal conditions of use, lithium manganese dioxide batteries are non-toxic.

SECTION 12 – ECOLOGICAL INFORMATION

Issues such as ecotoxicity, persistence and bioaccumulation are not applicable for articles.

SECTION 13 – DISPOSAL CONSIDERATIONS

Lithium iron disulfide batteries are not hazardous waste per the United States Resource Conservation and Recovery Act (RCRA) - 40 CFR Part 261 Subpart C. Dispose of in accordance with all applicable federal, state and local regulations.

SECTION 14 – TRANSPORT INFORMATION

In general, all batteries in all forms of transportation (ground, air, or ocean) must be packaged in a safe and responsible manner. Regulatory concerns from all agencies for safe packaging require that batteries be packaged in a manner that prevents short circuits and be contained in “strong outer packaging” that prevents spillage of contents. All original packaging for Energizer lithium batteries are compliant with these regulatory concerns.



Energizer lithium coin batteries are exempt from the classification as dangerous goods as they meet the requirements of the special provisions listed below. (Essentially, they are properly packaged and labeled, contain less than 1 gram of lithium and pass the tests defined in UN model regulation section 38.3).

Regulatory Body	Special Provisions
ADR	188, 230, 310, 636, 656
IMDG	188, 230, 310, 957
UN	UN 3090, UN 3091
US DOT	29, A54, A100, A101
IATA, ICAO	Packaging Instructions 968 - 970

Energizer is registered with CHEMTREC. In the event of an incident during transport call 1-800-424-9300 (North America) or 1-703-527-3887 (International).

A global lithium label chart is provided below to summarize the current global labeling requirements.

Label Summary Chart

Shipping Mode	Li content	Net quantity wt. of batteries per package	Battery Type			
AIR	0.3g to \leq 1g/cell 0.3g to \leq 2g/ battery	\leq 2.5 kg	L91, L92, L522	YES	YES	YES
	\leq 0.3g/cell	\leq 2.5kg	All Li Coin and 2L76	NO	YES	YES
	\leq 0.3g/cell	>2.5kg	All Li Coin and 2L76	YES	YES	YES
Land/ Sea only	All	All	All	NO	YES	YES

SECTION 15 - REGULATORY INFORMATION

Outside of the transportation requirements noted in Section 14, lithium manganese dioxide batteries marketed by Energizer Battery Manufacturing, Inc. are not regulated.

SARA/TITLE III - As an article, this battery and its contents are not subject to the requirements of the Emergency Planning and Community Right-To-Know Act.

SECTION 16 - OTHER INFORMATION

None.

PRODUCT SAFETY DATA SHEET

PRODUCT NAME: Energizer Battery **Type No.:** **Volts:** 3.0
TRADE NAMES: Coin/Button Lithium Manganese Dioxide Batteries **Approximate Weight:** 0.6 – 7.0 g
CHEMICAL SYSTEM: Lithium Manganese Dioxide **Designed for Recharge:** No

Energizer has prepared copyrighted Product Safety Datasheets to provide information on the different Eveready/Energizer battery systems. Batteries are articles as defined under the GHS and exempt from GHS classification criteria (Section 1.3.2.1.1 of the GHS). The information and recommendations set forth herein are made in good faith, for information only, and are believed to be accurate as of the date of preparation. However, ENERGIZER BATTERY MANUFACTURING, INC. MAKES NO WARRANTY, EITHER EXPRESS OR IMPLIED, WITH RESPECT TO THIS INFORMATION AND DISCLAIMS ALL LIABILITY FROM REFERENCE ON IT.

SECTION 1- MANUFACTURER INFORMATION

Manufactured for
Energizer Battery Manufacturing, Inc.
25225 Detroit Rd.
Westlake, OH 44145

Telephone Number for Information:
800-383-7323 (USA / CANADA)

Date Prepared: March 2015

SECTION 2 – HAZARDS IDENTIFICATION

GHS classification: N/A

Signal Word: N/A

Hazard Classification: N/A

Under normal conditions of use, the battery is hermetically sealed.

Ingestion: Swallowing may lead to serious injury or death in as little as 2 hours due to chemical burns and potential perforation of the esophagus. **Immediately see doctor; have doctor phone (202) 625-3333.** Do not induce vomiting or give food or drink.

Inhalation: Contents of an open battery can cause respiratory irritation.

Skin Contact: Contents of an open battery can cause skin irritation.

Eye Contact: Contents of an open battery can cause severe irritation.

SECTION 3 - INGREDIENTS

IMPORTANT NOTE: The battery should not be opened or burned. Exposure to the ingredients contained within or their combustion products could be harmful.

MATERIAL OR INGREDIENT	PEL (OSHA)	TLV (ACGIH)	%/wt.
Carbon Black (CAS# 1333-86-4)	3.5 mg/m ³ TWA	3.5 mg/m ³ TWA	0-1
1,2-Dimethoxyethane (CAS# 110-71-4)	None established	None established	0-6
1,3-Dioxolane (CAS# 646-06-0)	None established	None established	0-8
Graphite (CAS# 7782-42-5)	15 mg/m ³ TWA (total dust) 5 mg/m ³ TWA (respirable fraction)	2 mg/m ³ TWA (respirable fraction)	0-3
Lithium or Lithium Alloy (CAS# 7439-93-2)	None established	None established	1-6

Lithium Perchlorate (CAS# 7791-03-9)	None established	None established	0-3
Lithium Trifluoromethanesulfonate (CAS# 33454-82-9)	None established	None established	0-3
Lithium Trifluoromethanesulfonimide (CAS# 90076-65-6)	None established	None established	0-3
Manganese Dioxide (CAS# 1313-13-9)	5 mg/m ³ Ceiling (as Mn)	0.2 mg/m ³ TWA (as Mn)	12-42
Propylene Carbonate (CAS# 108-32-7)	None established	None established	0-8
Non-Hazardous Components:			
Steel (iron CAS# 65997-19-5)	None established	None established	20
Plastic and Other	None established	None established	Balance

SECTION 4 – FIRST AID MEASURES

Ingestion: Swallowing may lead to serious injury or death in as little as 2 hours due to chemical burns and potential perforation of the esophagus. **Immediately see doctor; have doctor phone (202) 625-3333.** Do not induce vomiting or give food or drink.

Inhalation: Provide fresh air and seek medical attention.

Skin Contact: Remove contaminated clothing and wash skin with soap and water.

Eye Contact: Immediately flush eyes thoroughly with water for at least 15 minutes, lifting upper and lower lids, until no evidence of the chemical remains. Seek medical attention.

Note: Carbon black is listed as a possible carcinogen by International Agency for Research on Cancer (IARC).

SECTION 5- FIRE FIGHTING MEASURES

In case of fire where lithium batteries are present, flood area with water or smother with a Class D fire extinguishant appropriate for lithium metal, such as Lith-X. Water may not extinguish burning batteries but will cool the adjacent batteries and control the spread of fire. Burning batteries will burn themselves out. Virtually all fires involving lithium batteries can be controlled by flooding with water. However, the contents of the battery will react with water and form hydrogen gas. In a confined space, hydrogen gas can form an explosive mixture. In this situation, smothering agents are recommended. A smothering agent will extinguish burning lithium batteries.

Emergency Responders should wear self-contained breathing apparatus. Burning lithium manganese dioxide batteries produce toxic and corrosive lithium hydroxide fumes.

SECTION 6 - ACCIDENTAL RELEASE MEASURES

To cleanup leaking batteries:

Ventilation Requirements: Room ventilation may be required in areas where there are open or leaking batteries.

Respiratory Protection: Avoid exposure to electrolyte fumes from open or leaking batteries.

Eye Protection: Wear safety glasses with side shields if handling an open or leaking battery.

Gloves: Use neoprene or natural rubber gloves if handling an open or leaking battery.

Battery materials should be collected in a leak-proof container.

SECTION 7 - HANDLING AND STORAGE

Storage: Store in a cool, well ventilated area. Elevated temperatures can result in shortened battery life. In locations that handle large quantities of lithium batteries, such as warehouses, lithium batteries should be isolated from unnecessary combustibles.

Mechanical Containment: If potting or sealing the battery in an airtight or watertight container is required, consult your Energizer Battery Manufacturing, Inc. representative for precautionary suggestions. Do not obstruct safety release vents on batteries. Encapsulation of batteries will not allow cell venting and can cause high pressure rupture.

Handling: Accidental short circuit for a few seconds will not seriously affect the battery. Prolonged short circuit will cause the battery to lose energy, generate significant heat and can cause the safety release vent to open. Sources of short circuits include jumbled batteries in bulk containers, metal jewelry, metal covered tables or metal belts used for assembly of batteries into devices. Damaging a lithium battery may result in an internal short circuit.

The contents of an open battery, including a vented battery, when exposed to water, may result in a fire and/or explosion. Crushed or damaged batteries may result in a fire.

If soldering or welding to the battery is required, consult your Energizer representative for proper precautions to prevent seal damage or short circuit.

Charging: This battery is manufactured in a charged state. It is not designed for recharging. Recharging can cause battery leakage or, in some cases, high pressure rupture. Inadvertent charging can occur if a battery is installed backwards.

Labeling: If the Energizer label or package warnings are not visible, it is important to provide a package and/or device label stating:

WARNING: Battery can explode or leak and cause burns if installed backwards, disassembled, charged, or exposed to water, fire or high temperature.

Where accidental ingestion of small batteries is possible, the label should include:



(1) KEEP OUT OF REACH OF CHILDREN. Swallowing may lead to serious injury or death in as little as 2 hours due to chemical burns and potential perforation of the esophagus. **Immediately see doctor; have doctor phone (202) 625-3333.** Keep in original package until ready to use. Dispose of used batteries immediately.

SECTION 8 - EXPOSURE CONTROLS/PERSONAL PROTECTION

Ventilation Requirements: Not necessary under normal conditions.

Respiratory Protection: Not necessary under normal conditions.

Eye Protection: Not necessary under normal conditions.

Gloves: Not necessary under normal conditions.

SECTION 9 – PHYSICAL AND CHEMICAL PROPERTIES

Appearance (physical state, color, etc.):	Solid object
Upper Explosive Limits:	Not applicable for an Article
Lower Explosive Limits	Not applicable for an Article
Odor	No odor
Vapor Pressure (mm Hg @ 25°C)	Not applicable for an Article
Odor Threshold	No odor
Vapor Density (Air = 1)	Not applicable for an Article
pH	Not applicable for an Article

Density (g/cm ³)	2.0-3.0
Melting point/Freezing Point	Not applicable for an Article
Solubility in Water (% by weight)	Not applicable for an Article
Boiling Point @ 760 mm Hg (°C)	Not applicable for an Article
Flash Point	Not applicable for an Article
Evaporation Rate (Butyl Acetate = 1)	Not applicable for an Article
Flammability	Not applicable for an Article
Partition Coefficient	Not applicable for an Article
Auto-ignition Temperature	Not applicable for an Article
Decomposition Temperature	Not applicable for an Article
Viscosity	Not applicable for an Article

SECTION 10 – STABILITY AND REACTIVITY

Lithium manganese dioxide batteries contain no sulfides or cyanides and they do not meet any other reactivity criteria including “reacts violently with water” and therefore do not meet any of the criteria established in 40 CFR 261.2 for reactivity.

SECTION 11 – TOXICOLOGICAL INFORMATION

Under normal conditions of use, lithium manganese dioxide batteries are non-toxic.

SECTION 12 – ECOLOGICAL INFORMATION

Issues such as ecotoxicity, persistence and bioaccumulation are not applicable for articles.

SECTION 13 – DISPOSAL CONSIDERATIONS

Lithium iron disulfide batteries are not hazardous waste per the United States Resource Conservation and Recovery Act (RCRA) - 40 CFR Part 261 Subpart C. Dispose of in accordance with all applicable federal, state and local regulations.

SECTION 14 – TRANSPORT INFORMATION

In general, all batteries in all forms of transportation (ground, air, or ocean) must be packaged in a safe and responsible manner. Regulatory concerns from all agencies for safe packaging require that batteries be packaged in a manner that prevents short circuits and be contained in “strong outer packaging” that prevents spillage of contents. All original packaging for Energizer lithium batteries are compliant with these regulatory concerns.



Energizer lithium coin batteries are exempt from the classification as dangerous goods as they meet the requirements of the special provisions listed below. (Essentially, they are properly packaged and labeled, contain less than 1 gram of lithium and pass the tests defined in UN model regulation section 38.3).

Regulatory Body	Special Provisions
ADR	188, 230, 310, 636, 656
IMDG	188, 230, 310, 957
UN	UN 3090, UN 3091
US DOT	29, A54, A100, A101
IATA, ICAO	Packaging Instructions 968 - 970

Energizer is registered with CHEMTREC. In the event of an incident during transport call 1-800-424-9300 (North America) or 1-703-527-3887 (International).

A global lithium label chart is provided below to summarize the current global labeling requirements.

Label Summary Chart

Shipping Mode	Li content	Net quantity wt. of batteries per package	Battery Type			
AIR	0.3g to \leq 1g/cell 0.3g to \leq 2g/ battery	\leq 2.5 kg	L91, L92, L522	YES	YES	YES
	\leq 0.3g/cell	\leq 2.5kg	All Li Coin and 2L76	NO	YES	YES
	\leq 0.3g/cell	>2.5kg	All Li Coin and 2L76	YES	YES	YES
Land/ Sea only	All	All	All	NO	YES	YES

SECTION 15 - REGULATORY INFORMATION

Outside of the transportation requirements noted in Section 14, lithium manganese dioxide batteries marketed by Energizer Battery Manufacturing, Inc. are not regulated.

SARA/TITLE III - As an article, this battery and its contents are not subject to the requirements of the Emergency Planning and Community Right-To-Know Act.

SECTION 16 - OTHER INFORMATION

None.

PRODUCT SAFETY DATA SHEET**PRODUCT NAME:** Energizer Battery**Type No.:****Volts:** 3.0**TRADE NAMES:** Coin/Button Lithium Manganese Dioxide Batteries**Approximate Weight:** 0.6 – 7.0 g**CHEMICAL SYSTEM:** Lithium Manganese Dioxide**Designed for Recharge:** No

Energizer has prepared copyrighted Product Safety Datasheets to provide information on the different Eveready/Energizer battery systems. Batteries are articles as defined under the GHS and exempt from GHS classification criteria (Section 1.3.2.1.1 of the GHS). The information and recommendations set forth herein are made in good faith, for information only, and are believed to be accurate as of the date of preparation. However, ENERGIZER BATTERY MANUFACTURING, INC. MAKES NO WARRANTY, EITHER EXPRESS OR IMPLIED, WITH RESPECT TO THIS INFORMATION AND DISCLAIMS ALL LIABILITY FROM REFERENCE ON IT.

SECTION 1- MANUFACTURER INFORMATION

Manufactured for
Energizer Battery Manufacturing, Inc.
25225 Detroit Rd.
Westlake, OH 44145

Telephone Number for Information:
800-383-7323 (USA / CANADA)

Date Prepared: March 2015

SECTION 2 – HAZARDS IDENTIFICATION**GHS classification:** N/A**Signal Word:** N/A**Hazard Classification:** N/A

Under normal conditions of use, the battery is hermetically sealed.

Ingestion: Swallowing may lead to serious injury or death in as little as 2 hours due to chemical burns and potential perforation of the esophagus. **Immediately see doctor; have doctor phone (202) 625-3333.** Do not induce vomiting or give food or drink.

Inhalation: Contents of an open battery can cause respiratory irritation.

Skin Contact: Contents of an open battery can cause skin irritation.

Eye Contact: Contents of an open battery can cause severe irritation.

SECTION 3 - INGREDIENTS

IMPORTANT NOTE: The battery should not be opened or burned. Exposure to the ingredients contained within or their combustion products could be harmful.

MATERIAL OR INGREDIENT	PEL (OSHA)	TLV (ACGIH)	%/wt.
Carbon Black (CAS# 1333-86-4)	3.5 mg/m ³ TWA	3.5 mg/m ³ TWA	0-1
1,2-Dimethoxyethane (CAS# 110-71-4)	None established	None established	0-6
1,3-Dioxolane (CAS# 646-06-0)	None established	None established	0-8
Graphite (CAS# 7782-42-5)	15 mg/m ³ TWA (total dust) 5 mg/m ³ TWA (respirable fraction)	2 mg/m ³ TWA (respirable fraction)	0-3
Lithium or Lithium Alloy (CAS# 7439-93-2)	None established	None established	1-6

Lithium Perchlorate (CAS# 7791-03-9)	None established	None established	0-3
Lithium Trifluoromethanesulfonate (CAS# 33454-82-9)	None established	None established	0-3
Lithium Trifluoromethanesulfonimide (CAS# 90076-65-6)	None established	None established	0-3
Manganese Dioxide (CAS# 1313-13-9)	5 mg/m ³ Ceiling (as Mn)	0.2 mg/m ³ TWA (as Mn)	12-42
Propylene Carbonate (CAS# 108-32-7)	None established	None established	0-8
Non-Hazardous Components:			
Steel (iron CAS# 65997-19-5)	None established	None established	20
Plastic and Other	None established	None established	Balance

SECTION 4 – FIRST AID MEASURES

Ingestion: Swallowing may lead to serious injury or death in as little as 2 hours due to chemical burns and potential perforation of the esophagus. **Immediately see doctor; have doctor phone (202) 625-3333.** Do not induce vomiting or give food or drink.

Inhalation: Provide fresh air and seek medical attention.

Skin Contact: Remove contaminated clothing and wash skin with soap and water.

Eye Contact: Immediately flush eyes thoroughly with water for at least 15 minutes, lifting upper and lower lids, until no evidence of the chemical remains. Seek medical attention.

Note: Carbon black is listed as a possible carcinogen by International Agency for Research on Cancer (IARC).

SECTION 5- FIRE FIGHTING MEASURES

In case of fire where lithium batteries are present, flood area with water or smother with a Class D fire extinguishant appropriate for lithium metal, such as Lith-X. Water may not extinguish burning batteries but will cool the adjacent batteries and control the spread of fire. Burning batteries will burn themselves out. Virtually all fires involving lithium batteries can be controlled by flooding with water. However, the contents of the battery will react with water and form hydrogen gas. In a confined space, hydrogen gas can form an explosive mixture. In this situation, smothering agents are recommended. A smothering agent will extinguish burning lithium batteries.

Emergency Responders should wear self-contained breathing apparatus. Burning lithium manganese dioxide batteries produce toxic and corrosive lithium hydroxide fumes.

SECTION 6 - ACCIDENTAL RELEASE MEASURES

To cleanup leaking batteries:

Ventilation Requirements: Room ventilation may be required in areas where there are open or leaking batteries.

Respiratory Protection: Avoid exposure to electrolyte fumes from open or leaking batteries.

Eye Protection: Wear safety glasses with side shields if handling an open or leaking battery.

Gloves: Use neoprene or natural rubber gloves if handling an open or leaking battery.

Battery materials should be collected in a leak-proof container.

SECTION 7 - HANDLING AND STORAGE

Storage: Store in a cool, well ventilated area. Elevated temperatures can result in shortened battery life. In locations that handle large quantities of lithium batteries, such as warehouses, lithium batteries should be isolated from unnecessary combustibles.

Mechanical Containment: If potting or sealing the battery in an airtight or watertight container is required, consult your Energizer Battery Manufacturing, Inc. representative for precautionary suggestions. Do not obstruct safety release vents on batteries. Encapsulation of batteries will not allow cell venting and can cause high pressure rupture.

Handling: Accidental short circuit for a few seconds will not seriously affect the battery. Prolonged short circuit will cause the battery to lose energy, generate significant heat and can cause the safety release vent to open. Sources of short circuits include jumbled batteries in bulk containers, metal jewelry, metal covered tables or metal belts used for assembly of batteries into devices. Damaging a lithium battery may result in an internal short circuit.

The contents of an open battery, including a vented battery, when exposed to water, may result in a fire and/or explosion. Crushed or damaged batteries may result in a fire.

If soldering or welding to the battery is required, consult your Energizer representative for proper precautions to prevent seal damage or short circuit.

Charging: This battery is manufactured in a charged state. It is not designed for recharging. Recharging can cause battery leakage or, in some cases, high pressure rupture. Inadvertent charging can occur if a battery is installed backwards.

Labeling: If the Energizer label or package warnings are not visible, it is important to provide a package and/or device label stating:

WARNING: Battery can explode or leak and cause burns if installed backwards, disassembled, charged, or exposed to water, fire or high temperature.

Where accidental ingestion of small batteries is possible, the label should include:



(1) KEEP OUT OF REACH OF CHILDREN. Swallowing may lead to serious injury or death in as little as 2 hours due to chemical burns and potential perforation of the esophagus. **Immediately see doctor; have doctor phone (202) 625-3333.** Keep in original package until ready to use. Dispose of used batteries immediately.

SECTION 8 - EXPOSURE CONTROLS/PERSONAL PROTECTION

Ventilation Requirements: Not necessary under normal conditions.

Respiratory Protection: Not necessary under normal conditions.

Eye Protection: Not necessary under normal conditions.

Gloves: Not necessary under normal conditions.

SECTION 9 – PHYSICAL AND CHEMICAL PROPERTIES

Appearance (physical state, color, etc.):	Solid object
Upper Explosive Limits:	Not applicable for an Article
Lower Explosive Limits	Not applicable for an Article
Odor	No odor
Vapor Pressure (mm Hg @ 25°C)	Not applicable for an Article
Odor Threshold	No odor
Vapor Density (Air = 1)	Not applicable for an Article
pH	Not applicable for an Article

Density (g/cm ³)	2.0-3.0
Melting point/Freezing Point	Not applicable for an Article
Solubility in Water (% by weight)	Not applicable for an Article
Boiling Point @ 760 mm Hg (°C)	Not applicable for an Article
Flash Point	Not applicable for an Article
Evaporation Rate (Butyl Acetate = 1)	Not applicable for an Article
Flammability	Not applicable for an Article
Partition Coefficient	Not applicable for an Article
Auto-ignition Temperature	Not applicable for an Article
Decomposition Temperature	Not applicable for an Article
Viscosity	Not applicable for an Article

SECTION 10 – STABILITY AND REACTIVITY

Lithium manganese dioxide batteries contain no sulfides or cyanides and they do not meet any other reactivity criteria including “reacts violently with water” and therefore do not meet any of the criteria established in 40 CFR 261.2 for reactivity.

SECTION 11 – TOXICOLOGICAL INFORMATION

Under normal conditions of use, lithium manganese dioxide batteries are non-toxic.

SECTION 12 – ECOLOGICAL INFORMATION

Issues such as ecotoxicity, persistence and bioaccumulation are not applicable for articles.

SECTION 13 – DISPOSAL CONSIDERATIONS

Lithium iron disulfide batteries are not hazardous waste per the United States Resource Conservation and Recovery Act (RCRA) - 40 CFR Part 261 Subpart C. Dispose of in accordance with all applicable federal, state and local regulations.

SECTION 14 – TRANSPORT INFORMATION

In general, all batteries in all forms of transportation (ground, air, or ocean) must be packaged in a safe and responsible manner. Regulatory concerns from all agencies for safe packaging require that batteries be packaged in a manner that prevents short circuits and be contained in “strong outer packaging” that prevents spillage of contents. All original packaging for Energizer lithium batteries are compliant with these regulatory concerns.



Energizer lithium coin batteries are exempt from the classification as dangerous goods as they meet the requirements of the special provisions listed below. (Essentially, they are properly packaged and labeled, contain less than 1 gram of lithium and pass the tests defined in UN model regulation section 38.3).

Regulatory Body	Special Provisions
ADR	188, 230, 310, 636, 656
IMDG	188, 230, 310, 957
UN	UN 3090, UN 3091
US DOT	29, A54, A100, A101
IATA, ICAO	Packaging Instructions 968 - 970

Energizer is registered with CHEMTREC. In the event of an incident during transport call 1-800-424-9300 (North America) or 1-703-527-3887 (International).

A global lithium label chart is provided below to summarize the current global labeling requirements.

Label Summary Chart

Shipping Mode	Li content	Net quantity wt. of batteries per package	Battery Type			
AIR	0.3g to \leq 1g/cell 0.3g to \leq 2g/ battery	\leq 2.5 kg	L91, L92, L522	YES	YES	YES
	\leq 0.3g/cell	\leq 2.5kg	All Li Coin and 2L76	NO	YES	YES
	\leq 0.3g/cell	>2.5kg	All Li Coin and 2L76	YES	YES	YES
Land/ Sea only	All	All	All	NO	YES	YES

SECTION 15 - REGULATORY INFORMATION

Outside of the transportation requirements noted in Section 14, lithium manganese dioxide batteries marketed by Energizer Battery Manufacturing, Inc. are not regulated.

SARA/TITLE III - As an article, this battery and its contents are not subject to the requirements of the Emergency Planning and Community Right-To-Know Act.

SECTION 16 - OTHER INFORMATION

None.

PRODUCT SAFETY DATA SHEET**PRODUCT NAME:** Energizer Battery**Type No.:****Volts:** 3.0**TRADE NAMES:** Coin/Button Lithium Manganese Dioxide Batteries**Approximate Weight:** 0.6 – 7.0 g**CHEMICAL SYSTEM:** Lithium Manganese Dioxide**Designed for Recharge:** No

Energizer has prepared copyrighted Product Safety Datasheets to provide information on the different Eveready/Energizer battery systems. Batteries are articles as defined under the GHS and exempt from GHS classification criteria (Section 1.3.2.1.1 of the GHS). The information and recommendations set forth herein are made in good faith, for information only, and are believed to be accurate as of the date of preparation. However, ENERGIZER BATTERY MANUFACTURING, INC. MAKES NO WARRANTY, EITHER EXPRESS OR IMPLIED, WITH RESPECT TO THIS INFORMATION AND DISCLAIMS ALL LIABILITY FROM REFERENCE ON IT.

SECTION 1- MANUFACTURER INFORMATIONManufactured for
Energizer Battery Manufacturing, Inc.
25225 Detroit Rd.
Westlake, OH 44145Telephone Number for Information:
800-383-7323 (USA / CANADA)

Date Prepared: March 2015

SECTION 2 – HAZARDS IDENTIFICATION**GHS classification:** N/A**Signal Word:** N/A**Hazard Classification:** N/A

Under normal conditions of use, the battery is hermetically sealed.

Ingestion: Swallowing may lead to serious injury or death in as little as 2 hours due to chemical burns and potential perforation of the esophagus. **Immediately see doctor; have doctor phone (202) 625-3333.** Do not induce vomiting or give food or drink.**Inhalation:** Contents of an open battery can cause respiratory irritation.**Skin Contact:** Contents of an open battery can cause skin irritation.**Eye Contact:** Contents of an open battery can cause severe irritation.**SECTION 3 - INGREDIENTS****IMPORTANT NOTE:** The battery should not be opened or burned. Exposure to the ingredients contained within or their combustion products could be harmful.

MATERIAL OR INGREDIENT	PEL (OSHA)	TLV (ACGIH)	%/wt.
Carbon Black (CAS# 1333-86-4)	3.5 mg/m ³ TWA	3.5 mg/m ³ TWA	0-1
1,2-Dimethoxyethane (CAS# 110-71-4)	None established	None established	0-6
1,3-Dioxolane (CAS# 646-06-0)	None established	None established	0-8
Graphite (CAS# 7782-42-5)	15 mg/m ³ TWA (total dust) 5 mg/m ³ TWA (respirable fraction)	2 mg/m ³ TWA (respirable fraction)	0-3
Lithium or Lithium Alloy (CAS# 7439-93-2)	None established	None established	1-6

Lithium Perchlorate (CAS# 7791-03-9)	None established	None established	0-3
Lithium Trifluoromethanesulfonate (CAS# 33454-82-9)	None established	None established	0-3
Lithium Trifluoromethanesulfonimide (CAS# 90076-65-6)	None established	None established	0-3
Manganese Dioxide (CAS# 1313-13-9)	5 mg/m ³ Ceiling (as Mn)	0.2 mg/m ³ TWA (as Mn)	12-42
Propylene Carbonate (CAS# 108-32-7)	None established	None established	0-8
Non-Hazardous Components:			
Steel (iron CAS# 65997-19-5)	None established	None established	20
Plastic and Other	None established	None established	Balance

SECTION 4 – FIRST AID MEASURES

Ingestion: Swallowing may lead to serious injury or death in as little as 2 hours due to chemical burns and potential perforation of the esophagus. **Immediately see doctor; have doctor phone (202) 625-3333.** Do not induce vomiting or give food or drink.

Inhalation: Provide fresh air and seek medical attention.

Skin Contact: Remove contaminated clothing and wash skin with soap and water.

Eye Contact: Immediately flush eyes thoroughly with water for at least 15 minutes, lifting upper and lower lids, until no evidence of the chemical remains. Seek medical attention.

Note: Carbon black is listed as a possible carcinogen by International Agency for Research on Cancer (IARC).

SECTION 5- FIRE FIGHTING MEASURES

In case of fire where lithium batteries are present, flood area with water or smother with a Class D fire extinguishant appropriate for lithium metal, such as Lith-X. Water may not extinguish burning batteries but will cool the adjacent batteries and control the spread of fire. Burning batteries will burn themselves out. Virtually all fires involving lithium batteries can be controlled by flooding with water. However, the contents of the battery will react with water and form hydrogen gas. In a confined space, hydrogen gas can form an explosive mixture. In this situation, smothering agents are recommended. A smothering agent will extinguish burning lithium batteries.

Emergency Responders should wear self-contained breathing apparatus. Burning lithium manganese dioxide batteries produce toxic and corrosive lithium hydroxide fumes.

SECTION 6 - ACCIDENTAL RELEASE MEASURES

To cleanup leaking batteries:

Ventilation Requirements: Room ventilation may be required in areas where there are open or leaking batteries.

Respiratory Protection: Avoid exposure to electrolyte fumes from open or leaking batteries.

Eye Protection: Wear safety glasses with side shields if handling an open or leaking battery.

Gloves: Use neoprene or natural rubber gloves if handling an open or leaking battery.

Battery materials should be collected in a leak-proof container.

SECTION 7 - HANDLING AND STORAGE

Storage: Store in a cool, well ventilated area. Elevated temperatures can result in shortened battery life. In locations that handle large quantities of lithium batteries, such as warehouses, lithium batteries should be isolated from unnecessary combustibles.

Mechanical Containment: If potting or sealing the battery in an airtight or watertight container is required, consult your Energizer Battery Manufacturing, Inc. representative for precautionary suggestions. Do not obstruct safety release vents on batteries. Encapsulation of batteries will not allow cell venting and can cause high pressure rupture.

Handling: Accidental short circuit for a few seconds will not seriously affect the battery. Prolonged short circuit will cause the battery to lose energy, generate significant heat and can cause the safety release vent to open. Sources of short circuits include jumbled batteries in bulk containers, metal jewelry, metal covered tables or metal belts used for assembly of batteries into devices. Damaging a lithium battery may result in an internal short circuit.

The contents of an open battery, including a vented battery, when exposed to water, may result in a fire and/or explosion. Crushed or damaged batteries may result in a fire.

If soldering or welding to the battery is required, consult your Energizer representative for proper precautions to prevent seal damage or short circuit.

Charging: This battery is manufactured in a charged state. It is not designed for recharging. Recharging can cause battery leakage or, in some cases, high pressure rupture. Inadvertent charging can occur if a battery is installed backwards.

Labeling: If the Energizer label or package warnings are not visible, it is important to provide a package and/or device label stating:

WARNING: Battery can explode or leak and cause burns if installed backwards, disassembled, charged, or exposed to water, fire or high temperature.

Where accidental ingestion of small batteries is possible, the label should include:



(1) KEEP OUT OF REACH OF CHILDREN. Swallowing may lead to serious injury or death in as little as 2 hours due to chemical burns and potential perforation of the esophagus. **Immediately see doctor; have doctor phone (202) 625-3333.** Keep in original package until ready to use. Dispose of used batteries immediately.

SECTION 8 - EXPOSURE CONTROLS/PERSONAL PROTECTION

Ventilation Requirements: Not necessary under normal conditions.

Respiratory Protection: Not necessary under normal conditions.

Eye Protection: Not necessary under normal conditions.

Gloves: Not necessary under normal conditions.

SECTION 9 – PHYSICAL AND CHEMICAL PROPERTIES

Appearance (physical state, color, etc.):	Solid object
Upper Explosive Limits:	Not applicable for an Article
Lower Explosive Limits	Not applicable for an Article
Odor	No odor
Vapor Pressure (mm Hg @ 25°C)	Not applicable for an Article
Odor Threshold	No odor
Vapor Density (Air = 1)	Not applicable for an Article
pH	Not applicable for an Article

Density (g/cm ³)	2.0-3.0
Melting point/Freezing Point	Not applicable for an Article
Solubility in Water (% by weight)	Not applicable for an Article
Boiling Point @ 760 mm Hg (°C)	Not applicable for an Article
Flash Point	Not applicable for an Article
Evaporation Rate (Butyl Acetate = 1)	Not applicable for an Article
Flammability	Not applicable for an Article
Partition Coefficient	Not applicable for an Article
Auto-ignition Temperature	Not applicable for an Article
Decomposition Temperature	Not applicable for an Article
Viscosity	Not applicable for an Article

SECTION 10 – STABILITY AND REACTIVITY

Lithium manganese dioxide batteries contain no sulfides or cyanides and they do not meet any other reactivity criteria including “reacts violently with water” and therefore do not meet any of the criteria established in 40 CFR 261.2 for reactivity.

SECTION 11 – TOXICOLOGICAL INFORMATION

Under normal conditions of use, lithium manganese dioxide batteries are non-toxic.

SECTION 12 – ECOLOGICAL INFORMATION

Issues such as ecotoxicity, persistence and bioaccumulation are not applicable for articles.

SECTION 13 – DISPOSAL CONSIDERATIONS

Lithium iron disulfide batteries are not hazardous waste per the United States Resource Conservation and Recovery Act (RCRA) - 40 CFR Part 261 Subpart C. Dispose of in accordance with all applicable federal, state and local regulations.

SECTION 14 – TRANSPORT INFORMATION

In general, all batteries in all forms of transportation (ground, air, or ocean) must be packaged in a safe and responsible manner. Regulatory concerns from all agencies for safe packaging require that batteries be packaged in a manner that prevents short circuits and be contained in “strong outer packaging” that prevents spillage of contents. All original packaging for Energizer lithium batteries are compliant with these regulatory concerns.



Energizer lithium coin batteries are exempt from the classification as dangerous goods as they meet the requirements of the special provisions listed below. (Essentially, they are properly packaged and labeled, contain less than 1 gram of lithium and pass the tests defined in UN model regulation section 38.3).

Regulatory Body	Special Provisions
ADR	188, 230, 310, 636, 656
IMDG	188, 230, 310, 957
UN	UN 3090, UN 3091
US DOT	29, A54, A100, A101
IATA, ICAO	Packaging Instructions 968 - 970

Energizer is registered with CHEMTREC. In the event of an incident during transport call 1-800-424-9300 (North America) or 1-703-527-3887 (International).

A global lithium label chart is provided below to summarize the current global labeling requirements.

Label Summary Chart

Shipping Mode	Li content	Net quantity wt. of batteries per package	Battery Type			
AIR	0.3g to ≤ 1 g/cell 0.3g to ≤ 2 g/ battery	≤ 2.5 kg	L91, L92, L522	YES	YES	YES
	≤ 0.3 g/cell	≤ 2.5 kg	All Li Coin and 2L76	NO	YES	YES
	≤ 0.3 g/cell	> 2.5 kg	All Li Coin and 2L76	YES	YES	YES
Land/ Sea only	All	All	All	NO	YES	YES

SECTION 15 - REGULATORY INFORMATION

Outside of the transportation requirements noted in Section 14, lithium manganese dioxide batteries marketed by Energizer Battery Manufacturing, Inc. are not regulated.

SARA/TITLE III - As an article, this battery and its contents are not subject to the requirements of the Emergency Planning and Community Right-To-Know Act.

SECTION 16 - OTHER INFORMATION

None.

PRODUCT SAFETY DATA SHEET**PRODUCT NAME:** Energizer Battery**Type No.:****Volts:** 3.0**TRADE NAMES:** Coin/Button Lithium Manganese Dioxide Batteries**Approximate Weight:** 0.6 – 7.0 g**CHEMICAL SYSTEM:** Lithium Manganese Dioxide**Designed for Recharge:** No

Energizer has prepared copyrighted Product Safety Datasheets to provide information on the different Eveready/Energizer battery systems. Batteries are articles as defined under the GHS and exempt from GHS classification criteria (Section 1.3.2.1.1 of the GHS). The information and recommendations set forth herein are made in good faith, for information only, and are believed to be accurate as of the date of preparation. However, ENERGIZER BATTERY MANUFACTURING, INC. MAKES NO WARRANTY, EITHER EXPRESS OR IMPLIED, WITH RESPECT TO THIS INFORMATION AND DISCLAIMS ALL LIABILITY FROM REFERENCE ON IT.

SECTION 1- MANUFACTURER INFORMATIONManufactured for
Energizer Battery Manufacturing, Inc.
25225 Detroit Rd.
Westlake, OH 44145Telephone Number for Information:
800-383-7323 (USA / CANADA)

Date Prepared: March 2015

SECTION 2 – HAZARDS IDENTIFICATION**GHS classification:** N/A**Signal Word:** N/A**Hazard Classification:** N/A

Under normal conditions of use, the battery is hermetically sealed.

Ingestion: Swallowing may lead to serious injury or death in as little as 2 hours due to chemical burns and potential perforation of the esophagus. **Immediately see doctor; have doctor phone (202) 625-3333.** Do not induce vomiting or give food or drink.**Inhalation:** Contents of an open battery can cause respiratory irritation.**Skin Contact:** Contents of an open battery can cause skin irritation.**Eye Contact:** Contents of an open battery can cause severe irritation.**SECTION 3 - INGREDIENTS****IMPORTANT NOTE:** The battery should not be opened or burned. Exposure to the ingredients contained within or their combustion products could be harmful.

MATERIAL OR INGREDIENT	PEL (OSHA)	TLV (ACGIH)	%/wt.
Carbon Black (CAS# 1333-86-4)	3.5 mg/m ³ TWA	3.5 mg/m ³ TWA	0-1
1,2-Dimethoxyethane (CAS# 110-71-4)	None established	None established	0-6
1,3-Dioxolane (CAS# 646-06-0)	None established	None established	0-8
Graphite (CAS# 7782-42-5)	15 mg/m ³ TWA (total dust) 5 mg/m ³ TWA (respirable fraction)	2 mg/m ³ TWA (respirable fraction)	0-3
Lithium or Lithium Alloy (CAS# 7439-93-2)	None established	None established	1-6

Lithium Perchlorate (CAS# 7791-03-9)	None established	None established	0-3
Lithium Trifluoromethanesulfonate (CAS# 33454-82-9)	None established	None established	0-3
Lithium Trifluoromethanesulfonimide (CAS# 90076-65-6)	None established	None established	0-3
Manganese Dioxide (CAS# 1313-13-9)	5 mg/m ³ Ceiling (as Mn)	0.2 mg/m ³ TWA (as Mn)	12-42
Propylene Carbonate (CAS# 108-32-7)	None established	None established	0-8
Non-Hazardous Components:			
Steel (iron CAS# 65997-19-5)	None established	None established	20
Plastic and Other	None established	None established	Balance

SECTION 4 – FIRST AID MEASURES

Ingestion: Swallowing may lead to serious injury or death in as little as 2 hours due to chemical burns and potential perforation of the esophagus. **Immediately see doctor; have doctor phone (202) 625-3333.** Do not induce vomiting or give food or drink.

Inhalation: Provide fresh air and seek medical attention.

Skin Contact: Remove contaminated clothing and wash skin with soap and water.

Eye Contact: Immediately flush eyes thoroughly with water for at least 15 minutes, lifting upper and lower lids, until no evidence of the chemical remains. Seek medical attention.

Note: Carbon black is listed as a possible carcinogen by International Agency for Research on Cancer (IARC).

SECTION 5- FIRE FIGHTING MEASURES

In case of fire where lithium batteries are present, flood area with water or smother with a Class D fire extinguishant appropriate for lithium metal, such as Lith-X. Water may not extinguish burning batteries but will cool the adjacent batteries and control the spread of fire. Burning batteries will burn themselves out. Virtually all fires involving lithium batteries can be controlled by flooding with water. However, the contents of the battery will react with water and form hydrogen gas. In a confined space, hydrogen gas can form an explosive mixture. In this situation, smothering agents are recommended. A smothering agent will extinguish burning lithium batteries.

Emergency Responders should wear self-contained breathing apparatus. Burning lithium manganese dioxide batteries produce toxic and corrosive lithium hydroxide fumes.

SECTION 6 - ACCIDENTAL RELEASE MEASURES

To cleanup leaking batteries:

Ventilation Requirements: Room ventilation may be required in areas where there are open or leaking batteries.

Respiratory Protection: Avoid exposure to electrolyte fumes from open or leaking batteries.

Eye Protection: Wear safety glasses with side shields if handling an open or leaking battery.

Gloves: Use neoprene or natural rubber gloves if handling an open or leaking battery.

Battery materials should be collected in a leak-proof container.

SECTION 7 - HANDLING AND STORAGE

Storage: Store in a cool, well ventilated area. Elevated temperatures can result in shortened battery life. In locations that handle large quantities of lithium batteries, such as warehouses, lithium batteries should be isolated from unnecessary combustibles.

Mechanical Containment: If potting or sealing the battery in an airtight or watertight container is required, consult your Energizer Battery Manufacturing, Inc. representative for precautionary suggestions. Do not obstruct safety release vents on batteries. Encapsulation of batteries will not allow cell venting and can cause high pressure rupture.

Handling: Accidental short circuit for a few seconds will not seriously affect the battery. Prolonged short circuit will cause the battery to lose energy, generate significant heat and can cause the safety release vent to open. Sources of short circuits include jumbled batteries in bulk containers, metal jewelry, metal covered tables or metal belts used for assembly of batteries into devices. Damaging a lithium battery may result in an internal short circuit.

The contents of an open battery, including a vented battery, when exposed to water, may result in a fire and/or explosion. Crushed or damaged batteries may result in a fire.

If soldering or welding to the battery is required, consult your Energizer representative for proper precautions to prevent seal damage or short circuit.

Charging: This battery is manufactured in a charged state. It is not designed for recharging. Recharging can cause battery leakage or, in some cases, high pressure rupture. Inadvertent charging can occur if a battery is installed backwards.

Labeling: If the Energizer label or package warnings are not visible, it is important to provide a package and/or device label stating:

WARNING: Battery can explode or leak and cause burns if installed backwards, disassembled, charged, or exposed to water, fire or high temperature.

Where accidental ingestion of small batteries is possible, the label should include:



(1) KEEP OUT OF REACH OF CHILDREN. Swallowing may lead to serious injury or death in as little as 2 hours due to chemical burns and potential perforation of the esophagus. **Immediately see doctor; have doctor phone (202) 625-3333.** Keep in original package until ready to use. Dispose of used batteries immediately.

SECTION 8 - EXPOSURE CONTROLS/PERSONAL PROTECTION

Ventilation Requirements: Not necessary under normal conditions.

Respiratory Protection: Not necessary under normal conditions.

Eye Protection: Not necessary under normal conditions.

Gloves: Not necessary under normal conditions.

SECTION 9 – PHYSICAL AND CHEMICAL PROPERTIES

Appearance (physical state, color, etc.):	Solid object
Upper Explosive Limits:	Not applicable for an Article
Lower Explosive Limits	Not applicable for an Article
Odor	No odor
Vapor Pressure (mm Hg @ 25°C)	Not applicable for an Article
Odor Threshold	No odor
Vapor Density (Air = 1)	Not applicable for an Article
pH	Not applicable for an Article

Density (g/cm ³)	2.0-3.0
Melting point/Freezing Point	Not applicable for an Article
Solubility in Water (% by weight)	Not applicable for an Article
Boiling Point @ 760 mm Hg (°C)	Not applicable for an Article
Flash Point	Not applicable for an Article
Evaporation Rate (Butyl Acetate = 1)	Not applicable for an Article
Flammability	Not applicable for an Article
Partition Coefficient	Not applicable for an Article
Auto-ignition Temperature	Not applicable for an Article
Decomposition Temperature	Not applicable for an Article
Viscosity	Not applicable for an Article

SECTION 10 – STABILITY AND REACTIVITY

Lithium manganese dioxide batteries contain no sulfides or cyanides and they do not meet any other reactivity criteria including “reacts violently with water” and therefore do not meet any of the criteria established in 40 CFR 261.2 for reactivity.

SECTION 11 – TOXICOLOGICAL INFORMATION

Under normal conditions of use, lithium manganese dioxide batteries are non-toxic.

SECTION 12 – ECOLOGICAL INFORMATION

Issues such as ecotoxicity, persistence and bioaccumulation are not applicable for articles.

SECTION 13 – DISPOSAL CONSIDERATIONS

Lithium iron disulfide batteries are not hazardous waste per the United States Resource Conservation and Recovery Act (RCRA) - 40 CFR Part 261 Subpart C. Dispose of in accordance with all applicable federal, state and local regulations.

SECTION 14 – TRANSPORT INFORMATION

In general, all batteries in all forms of transportation (ground, air, or ocean) must be packaged in a safe and responsible manner. Regulatory concerns from all agencies for safe packaging require that batteries be packaged in a manner that prevents short circuits and be contained in “strong outer packaging” that prevents spillage of contents. All original packaging for Energizer lithium batteries are compliant with these regulatory concerns.



Energizer lithium coin batteries are exempt from the classification as dangerous goods as they meet the requirements of the special provisions listed below. (Essentially, they are properly packaged and labeled, contain less than 1 gram of lithium and pass the tests defined in UN model regulation section 38.3).

Regulatory Body	Special Provisions
ADR	188, 230, 310, 636, 656
IMDG	188, 230, 310, 957
UN	UN 3090, UN 3091
US DOT	29, A54, A100, A101
IATA, ICAO	Packaging Instructions 968 - 970

Energizer is registered with CHEMTREC. In the event of an incident during transport call 1-800-424-9300 (North America) or 1-703-527-3887 (International).

A global lithium label chart is provided below to summarize the current global labeling requirements.

Label Summary Chart

Shipping Mode	Li content	Net quantity wt. of batteries per package	Battery Type			
AIR	0.3g to \leq 1g/cell 0.3g to \leq 2g/ battery	\leq 2.5 kg	L91, L92, L522	YES	YES	YES
	\leq 0.3g/cell	\leq 2.5kg	All Li Coin and 2L76	NO	YES	YES
	\leq 0.3g/cell	>2.5kg	All Li Coin and 2L76	YES	YES	YES
Land/ Sea only	All	All	All	NO	YES	YES

SECTION 15 - REGULATORY INFORMATION

Outside of the transportation requirements noted in Section 14, lithium manganese dioxide batteries marketed by Energizer Battery Manufacturing, Inc. are not regulated.

SARA/TITLE III - As an article, this battery and its contents are not subject to the requirements of the Emergency Planning and Community Right-To-Know Act.

SECTION 16 - OTHER INFORMATION

None.

PRODUCT SAFETY DATA SHEET**PRODUCT NAME:** Energizer Battery**Type No.:****Volts:** 3.0**TRADE NAMES:** Coin/Button Lithium Manganese Dioxide Batteries**Approximate Weight:** 0.6 – 7.0 g**CHEMICAL SYSTEM:** Lithium Manganese Dioxide**Designed for Recharge:** No

Energizer has prepared copyrighted Product Safety Datasheets to provide information on the different Eveready/Energizer battery systems. Batteries are articles as defined under the GHS and exempt from GHS classification criteria (Section 1.3.2.1.1 of the GHS). The information and recommendations set forth herein are made in good faith, for information only, and are believed to be accurate as of the date of preparation. However, ENERGIZER BATTERY MANUFACTURING, INC. MAKES NO WARRANTY, EITHER EXPRESS OR IMPLIED, WITH RESPECT TO THIS INFORMATION AND DISCLAIMS ALL LIABILITY FROM REFERENCE ON IT.

SECTION 1- MANUFACTURER INFORMATION

Manufactured for
Energizer Battery Manufacturing, Inc.
25225 Detroit Rd.
Westlake, OH 44145

Telephone Number for Information:
800-383-7323 (USA / CANADA)

Date Prepared: March 2015

SECTION 2 – HAZARDS IDENTIFICATION**GHS classification:** N/A**Signal Word:** N/A**Hazard Classification:** N/A

Under normal conditions of use, the battery is hermetically sealed.

Ingestion: Swallowing may lead to serious injury or death in as little as 2 hours due to chemical burns and potential perforation of the esophagus. **Immediately see doctor; have doctor phone (202) 625-3333.** Do not induce vomiting or give food or drink.

Inhalation: Contents of an open battery can cause respiratory irritation.

Skin Contact: Contents of an open battery can cause skin irritation.

Eye Contact: Contents of an open battery can cause severe irritation.

SECTION 3 - INGREDIENTS

IMPORTANT NOTE: The battery should not be opened or burned. Exposure to the ingredients contained within or their combustion products could be harmful.

MATERIAL OR INGREDIENT	PEL (OSHA)	TLV (ACGIH)	%/wt.
Carbon Black (CAS# 1333-86-4)	3.5 mg/m ³ TWA	3.5 mg/m ³ TWA	0-1
1,2-Dimethoxyethane (CAS# 110-71-4)	None established	None established	0-6
1,3-Dioxolane (CAS# 646-06-0)	None established	None established	0-8
Graphite (CAS# 7782-42-5)	15 mg/m ³ TWA (total dust) 5 mg/m ³ TWA (respirable fraction)	2 mg/m ³ TWA (respirable fraction)	0-3
Lithium or Lithium Alloy (CAS# 7439-93-2)	None established	None established	1-6

Lithium Perchlorate (CAS# 7791-03-9)	None established	None established	0-3
Lithium Trifluoromethanesulfonate (CAS# 33454-82-9)	None established	None established	0-3
Lithium Trifluoromethanesulfonimide (CAS# 90076-65-6)	None established	None established	0-3
Manganese Dioxide (CAS# 1313-13-9)	5 mg/m ³ Ceiling (as Mn)	0.2 mg/m ³ TWA (as Mn)	12-42
Propylene Carbonate (CAS# 108-32-7)	None established	None established	0-8
Non-Hazardous Components:			
Steel (iron CAS# 65997-19-5)	None established	None established	20
Plastic and Other	None established	None established	Balance

SECTION 4 – FIRST AID MEASURES

Ingestion: Swallowing may lead to serious injury or death in as little as 2 hours due to chemical burns and potential perforation of the esophagus. **Immediately see doctor; have doctor phone (202) 625-3333.** Do not induce vomiting or give food or drink.

Inhalation: Provide fresh air and seek medical attention.

Skin Contact: Remove contaminated clothing and wash skin with soap and water.

Eye Contact: Immediately flush eyes thoroughly with water for at least 15 minutes, lifting upper and lower lids, until no evidence of the chemical remains. Seek medical attention.

Note: Carbon black is listed as a possible carcinogen by International Agency for Research on Cancer (IARC).

SECTION 5- FIRE FIGHTING MEASURES

In case of fire where lithium batteries are present, flood area with water or smother with a Class D fire extinguishant appropriate for lithium metal, such as Lith-X. Water may not extinguish burning batteries but will cool the adjacent batteries and control the spread of fire. Burning batteries will burn themselves out. Virtually all fires involving lithium batteries can be controlled by flooding with water. However, the contents of the battery will react with water and form hydrogen gas. In a confined space, hydrogen gas can form an explosive mixture. In this situation, smothering agents are recommended. A smothering agent will extinguish burning lithium batteries.

Emergency Responders should wear self-contained breathing apparatus. Burning lithium manganese dioxide batteries produce toxic and corrosive lithium hydroxide fumes.

SECTION 6 - ACCIDENTAL RELEASE MEASURES

To cleanup leaking batteries:

Ventilation Requirements: Room ventilation may be required in areas where there are open or leaking batteries.

Respiratory Protection: Avoid exposure to electrolyte fumes from open or leaking batteries.

Eye Protection: Wear safety glasses with side shields if handling an open or leaking battery.

Gloves: Use neoprene or natural rubber gloves if handling an open or leaking battery.

Battery materials should be collected in a leak-proof container.

SECTION 7 - HANDLING AND STORAGE

Storage: Store in a cool, well ventilated area. Elevated temperatures can result in shortened battery life. In locations that handle large quantities of lithium batteries, such as warehouses, lithium batteries should be isolated from unnecessary combustibles.

Mechanical Containment: If potting or sealing the battery in an airtight or watertight container is required, consult your Energizer Battery Manufacturing, Inc. representative for precautionary suggestions. Do not obstruct safety release vents on batteries. Encapsulation of batteries will not allow cell venting and can cause high pressure rupture.

Handling: Accidental short circuit for a few seconds will not seriously affect the battery. Prolonged short circuit will cause the battery to lose energy, generate significant heat and can cause the safety release vent to open. Sources of short circuits include jumbled batteries in bulk containers, metal jewelry, metal covered tables or metal belts used for assembly of batteries into devices. Damaging a lithium battery may result in an internal short circuit.

The contents of an open battery, including a vented battery, when exposed to water, may result in a fire and/or explosion. Crushed or damaged batteries may result in a fire.

If soldering or welding to the battery is required, consult your Energizer representative for proper precautions to prevent seal damage or short circuit.

Charging: This battery is manufactured in a charged state. It is not designed for recharging. Recharging can cause battery leakage or, in some cases, high pressure rupture. Inadvertent charging can occur if a battery is installed backwards.

Labeling: If the Energizer label or package warnings are not visible, it is important to provide a package and/or device label stating:

WARNING: Battery can explode or leak and cause burns if installed backwards, disassembled, charged, or exposed to water, fire or high temperature.

Where accidental ingestion of small batteries is possible, the label should include:



(1) KEEP OUT OF REACH OF CHILDREN. Swallowing may lead to serious injury or death in as little as 2 hours due to chemical burns and potential perforation of the esophagus. **Immediately see doctor; have doctor phone (202) 625-3333.** Keep in original package until ready to use. Dispose of used batteries immediately.

SECTION 8 - EXPOSURE CONTROLS/PERSONAL PROTECTION

Ventilation Requirements: Not necessary under normal conditions.

Respiratory Protection: Not necessary under normal conditions.

Eye Protection: Not necessary under normal conditions.

Gloves: Not necessary under normal conditions.

SECTION 9 – PHYSICAL AND CHEMICAL PROPERTIES

Appearance (physical state, color, etc.):	Solid object
Upper Explosive Limits:	Not applicable for an Article
Lower Explosive Limits	Not applicable for an Article
Odor	No odor
Vapor Pressure (mm Hg @ 25°C)	Not applicable for an Article
Odor Threshold	No odor
Vapor Density (Air = 1)	Not applicable for an Article
pH	Not applicable for an Article

Density (g/cm ³)	2.0-3.0
Melting point/Freezing Point	Not applicable for an Article
Solubility in Water (% by weight)	Not applicable for an Article
Boiling Point @ 760 mm Hg (°C)	Not applicable for an Article
Flash Point	Not applicable for an Article
Evaporation Rate (Butyl Acetate = 1)	Not applicable for an Article
Flammability	Not applicable for an Article
Partition Coefficient	Not applicable for an Article
Auto-ignition Temperature	Not applicable for an Article
Decomposition Temperature	Not applicable for an Article
Viscosity	Not applicable for an Article

SECTION 10 – STABILITY AND REACTIVITY

Lithium manganese dioxide batteries contain no sulfides or cyanides and they do not meet any other reactivity criteria including “reacts violently with water” and therefore do not meet any of the criteria established in 40 CFR 261.2 for reactivity.

SECTION 11 – TOXICOLOGICAL INFORMATION

Under normal conditions of use, lithium manganese dioxide batteries are non-toxic.

SECTION 12 – ECOLOGICAL INFORMATION

Issues such as ecotoxicity, persistence and bioaccumulation are not applicable for articles.

SECTION 13 – DISPOSAL CONSIDERATIONS

Lithium iron disulfide batteries are not hazardous waste per the United States Resource Conservation and Recovery Act (RCRA) - 40 CFR Part 261 Subpart C. Dispose of in accordance with all applicable federal, state and local regulations.

SECTION 14 – TRANSPORT INFORMATION

In general, all batteries in all forms of transportation (ground, air, or ocean) must be packaged in a safe and responsible manner. Regulatory concerns from all agencies for safe packaging require that batteries be packaged in a manner that prevents short circuits and be contained in “strong outer packaging” that prevents spillage of contents. All original packaging for Energizer lithium batteries are compliant with these regulatory concerns.



Energizer lithium coin batteries are exempt from the classification as dangerous goods as they meet the requirements of the special provisions listed below. (Essentially, they are properly packaged and labeled, contain less than 1 gram of lithium and pass the tests defined in UN model regulation section 38.3).

Regulatory Body	Special Provisions
ADR	188, 230, 310, 636, 656
IMDG	188, 230, 310, 957
UN	UN 3090, UN 3091
US DOT	29, A54, A100, A101
IATA, ICAO	Packaging Instructions 968 - 970

Energizer is registered with CHEMTREC. In the event of an incident during transport call 1-800-424-9300 (North America) or 1-703-527-3887 (International).

A global lithium label chart is provided below to summarize the current global labeling requirements.

Label Summary Chart

Shipping Mode	Li content	Net quantity wt. of batteries per package	Battery Type			
AIR	0.3g to \leq 1g/cell 0.3g to \leq 2g/ battery	\leq 2.5 kg	L91, L92, L522	YES	YES	YES
	\leq 0.3g/cell	\leq 2.5kg	All Li Coin and 2L76	NO	YES	YES
	\leq 0.3g/cell	>2.5kg	All Li Coin and 2L76	YES	YES	YES
Land/ Sea only	All	All	All	NO	YES	YES

SECTION 15 - REGULATORY INFORMATION

Outside of the transportation requirements noted in Section 14, lithium manganese dioxide batteries marketed by Energizer Battery Manufacturing, Inc. are not regulated.

SARA/TITLE III - As an article, this battery and its contents are not subject to the requirements of the Emergency Planning and Community Right-To-Know Act.

SECTION 16 - OTHER INFORMATION

None.

PRODUCT SAFETY DATA SHEET**PRODUCT NAME:** Energizer Battery**Type No.:****Volts:** 3.0**TRADE NAMES:** Coin/Button Lithium Manganese Dioxide Batteries**Approximate Weight:** 0.6 – 7.0 g**CHEMICAL SYSTEM:** Lithium Manganese Dioxide**Designed for Recharge:** No

Energizer has prepared copyrighted Product Safety Datasheets to provide information on the different Eveready/Energizer battery systems. Batteries are articles as defined under the GHS and exempt from GHS classification criteria (Section 1.3.2.1.1 of the GHS). The information and recommendations set forth herein are made in good faith, for information only, and are believed to be accurate as of the date of preparation. However, ENERGIZER BATTERY MANUFACTURING, INC. MAKES NO WARRANTY, EITHER EXPRESS OR IMPLIED, WITH RESPECT TO THIS INFORMATION AND DISCLAIMS ALL LIABILITY FROM REFERENCE ON IT.

SECTION 1- MANUFACTURER INFORMATIONManufactured for
Energizer Battery Manufacturing, Inc.
25225 Detroit Rd.
Westlake, OH 44145Telephone Number for Information:
800-383-7323 (USA / CANADA)

Date Prepared: March 2015

SECTION 2 – HAZARDS IDENTIFICATION**GHS classification:** N/A**Signal Word:** N/A**Hazard Classification:** N/A

Under normal conditions of use, the battery is hermetically sealed.

Ingestion: Swallowing may lead to serious injury or death in as little as 2 hours due to chemical burns and potential perforation of the esophagus. **Immediately see doctor; have doctor phone (202) 625-3333.** Do not induce vomiting or give food or drink.**Inhalation:** Contents of an open battery can cause respiratory irritation.**Skin Contact:** Contents of an open battery can cause skin irritation.**Eye Contact:** Contents of an open battery can cause severe irritation.**SECTION 3 - INGREDIENTS****IMPORTANT NOTE:** The battery should not be opened or burned. Exposure to the ingredients contained within or their combustion products could be harmful.

MATERIAL OR INGREDIENT	PEL (OSHA)	TLV (ACGIH)	%/wt.
Carbon Black (CAS# 1333-86-4)	3.5 mg/m ³ TWA	3.5 mg/m ³ TWA	0-1
1,2-Dimethoxyethane (CAS# 110-71-4)	None established	None established	0-6
1,3-Dioxolane (CAS# 646-06-0)	None established	None established	0-8
Graphite (CAS# 7782-42-5)	15 mg/m ³ TWA (total dust) 5 mg/m ³ TWA (respirable fraction)	2 mg/m ³ TWA (respirable fraction)	0-3
Lithium or Lithium Alloy (CAS# 7439-93-2)	None established	None established	1-6

Lithium Perchlorate (CAS# 7791-03-9)	None established	None established	0-3
Lithium Trifluoromethanesulfonate (CAS# 33454-82-9)	None established	None established	0-3
Lithium Trifluoromethanesulfonimide (CAS# 90076-65-6)	None established	None established	0-3
Manganese Dioxide (CAS# 1313-13-9)	5 mg/m ³ Ceiling (as Mn)	0.2 mg/m ³ TWA (as Mn)	12-42
Propylene Carbonate (CAS# 108-32-7)	None established	None established	0-8
Non-Hazardous Components:			
Steel (iron CAS# 65997-19-5)	None established	None established	20
Plastic and Other	None established	None established	Balance

SECTION 4 – FIRST AID MEASURES

Ingestion: Swallowing may lead to serious injury or death in as little as 2 hours due to chemical burns and potential perforation of the esophagus. **Immediately see doctor; have doctor phone (202) 625-3333.** Do not induce vomiting or give food or drink.

Inhalation: Provide fresh air and seek medical attention.

Skin Contact: Remove contaminated clothing and wash skin with soap and water.

Eye Contact: Immediately flush eyes thoroughly with water for at least 15 minutes, lifting upper and lower lids, until no evidence of the chemical remains. Seek medical attention.

Note: Carbon black is listed as a possible carcinogen by International Agency for Research on Cancer (IARC).

SECTION 5- FIRE FIGHTING MEASURES

In case of fire where lithium batteries are present, flood area with water or smother with a Class D fire extinguishant appropriate for lithium metal, such as Lith-X. Water may not extinguish burning batteries but will cool the adjacent batteries and control the spread of fire. Burning batteries will burn themselves out. Virtually all fires involving lithium batteries can be controlled by flooding with water. However, the contents of the battery will react with water and form hydrogen gas. In a confined space, hydrogen gas can form an explosive mixture. In this situation, smothering agents are recommended. A smothering agent will extinguish burning lithium batteries.

Emergency Responders should wear self-contained breathing apparatus. Burning lithium manganese dioxide batteries produce toxic and corrosive lithium hydroxide fumes.

SECTION 6 - ACCIDENTAL RELEASE MEASURES

To cleanup leaking batteries:

Ventilation Requirements: Room ventilation may be required in areas where there are open or leaking batteries.

Respiratory Protection: Avoid exposure to electrolyte fumes from open or leaking batteries.

Eye Protection: Wear safety glasses with side shields if handling an open or leaking battery.

Gloves: Use neoprene or natural rubber gloves if handling an open or leaking battery.

Battery materials should be collected in a leak-proof container.

SECTION 7 - HANDLING AND STORAGE

Storage: Store in a cool, well ventilated area. Elevated temperatures can result in shortened battery life. In locations that handle large quantities of lithium batteries, such as warehouses, lithium batteries should be isolated from unnecessary combustibles.

Mechanical Containment: If potting or sealing the battery in an airtight or watertight container is required, consult your Energizer Battery Manufacturing, Inc. representative for precautionary suggestions. Do not obstruct safety release vents on batteries. Encapsulation of batteries will not allow cell venting and can cause high pressure rupture.

Handling: Accidental short circuit for a few seconds will not seriously affect the battery. Prolonged short circuit will cause the battery to lose energy, generate significant heat and can cause the safety release vent to open. Sources of short circuits include jumbled batteries in bulk containers, metal jewelry, metal covered tables or metal belts used for assembly of batteries into devices. Damaging a lithium battery may result in an internal short circuit.

The contents of an open battery, including a vented battery, when exposed to water, may result in a fire and/or explosion. Crushed or damaged batteries may result in a fire.

If soldering or welding to the battery is required, consult your Energizer representative for proper precautions to prevent seal damage or short circuit.

Charging: This battery is manufactured in a charged state. It is not designed for recharging. Recharging can cause battery leakage or, in some cases, high pressure rupture. Inadvertent charging can occur if a battery is installed backwards.

Labeling: If the Energizer label or package warnings are not visible, it is important to provide a package and/or device label stating:

WARNING: Battery can explode or leak and cause burns if installed backwards, disassembled, charged, or exposed to water, fire or high temperature.

Where accidental ingestion of small batteries is possible, the label should include:



(1) KEEP OUT OF REACH OF CHILDREN. Swallowing may lead to serious injury or death in as little as 2 hours due to chemical burns and potential perforation of the esophagus. **Immediately see doctor; have doctor phone (202) 625-3333.** Keep in original package until ready to use. Dispose of used batteries immediately.

SECTION 8 - EXPOSURE CONTROLS/PERSONAL PROTECTION

Ventilation Requirements: Not necessary under normal conditions.

Respiratory Protection: Not necessary under normal conditions.

Eye Protection: Not necessary under normal conditions.

Gloves: Not necessary under normal conditions.

SECTION 9 – PHYSICAL AND CHEMICAL PROPERTIES

Appearance (physical state, color, etc.):	Solid object
Upper Explosive Limits:	Not applicable for an Article
Lower Explosive Limits	Not applicable for an Article
Odor	No odor
Vapor Pressure (mm Hg @ 25°C)	Not applicable for an Article
Odor Threshold	No odor
Vapor Density (Air = 1)	Not applicable for an Article
pH	Not applicable for an Article

Density (g/cm ³)	2.0-3.0
Melting point/Freezing Point	Not applicable for an Article
Solubility in Water (% by weight)	Not applicable for an Article
Boiling Point @ 760 mm Hg (°C)	Not applicable for an Article
Flash Point	Not applicable for an Article
Evaporation Rate (Butyl Acetate = 1)	Not applicable for an Article
Flammability	Not applicable for an Article
Partition Coefficient	Not applicable for an Article
Auto-ignition Temperature	Not applicable for an Article
Decomposition Temperature	Not applicable for an Article
Viscosity	Not applicable for an Article

SECTION 10 – STABILITY AND REACTIVITY

Lithium manganese dioxide batteries contain no sulfides or cyanides and they do not meet any other reactivity criteria including “reacts violently with water” and therefore do not meet any of the criteria established in 40 CFR 261.2 for reactivity.

SECTION 11 – TOXICOLOGICAL INFORMATION

Under normal conditions of use, lithium manganese dioxide batteries are non-toxic.

SECTION 12 – ECOLOGICAL INFORMATION

Issues such as ecotoxicity, persistence and bioaccumulation are not applicable for articles.

SECTION 13 – DISPOSAL CONSIDERATIONS

Lithium iron disulfide batteries are not hazardous waste per the United States Resource Conservation and Recovery Act (RCRA) - 40 CFR Part 261 Subpart C. Dispose of in accordance with all applicable federal, state and local regulations.

SECTION 14 – TRANSPORT INFORMATION

In general, all batteries in all forms of transportation (ground, air, or ocean) must be packaged in a safe and responsible manner. Regulatory concerns from all agencies for safe packaging require that batteries be packaged in a manner that prevents short circuits and be contained in “strong outer packaging” that prevents spillage of contents. All original packaging for Energizer lithium batteries are compliant with these regulatory concerns.



Energizer lithium coin batteries are exempt from the classification as dangerous goods as they meet the requirements of the special provisions listed below. (Essentially, they are properly packaged and labeled, contain less than 1 gram of lithium and pass the tests defined in UN model regulation section 38.3).

Regulatory Body	Special Provisions
ADR	188, 230, 310, 636, 656
IMDG	188, 230, 310, 957
UN	UN 3090, UN 3091
US DOT	29, A54, A100, A101
IATA, ICAO	Packaging Instructions 968 - 970

Energizer is registered with CHEMTREC. In the event of an incident during transport call 1-800-424-9300 (North America) or 1-703-527-3887 (International).

A global lithium label chart is provided below to summarize the current global labeling requirements.

Label Summary Chart

Shipping Mode	Li content	Net quantity wt. of batteries per package	Battery Type			
AIR	0.3g to ≤ 1 g/cell 0.3g to ≤ 2 g/ battery	≤ 2.5 kg	L91, L92, L522	YES	YES	YES
	≤ 0.3 g/cell	≤ 2.5 kg	All Li Coin and 2L76	NO	YES	YES
	≤ 0.3 g/cell	> 2.5 kg	All Li Coin and 2L76	YES	YES	YES
Land/ Sea only	All	All	All	NO	YES	YES

SECTION 15 - REGULATORY INFORMATION

Outside of the transportation requirements noted in Section 14, lithium manganese dioxide batteries marketed by Energizer Battery Manufacturing, Inc. are not regulated.

SARA/TITLE III - As an article, this battery and its contents are not subject to the requirements of the Emergency Planning and Community Right-To-Know Act.

SECTION 16 - OTHER INFORMATION

None.

PRODUCT SAFETY DATA SHEET**PRODUCT NAME:** Energizer Battery**Type No.:****Volts:** 3.0**TRADE NAMES:** Coin/Button Lithium Manganese Dioxide Batteries**Approximate Weight:** 0.6 – 7.0 g**CHEMICAL SYSTEM:** Lithium Manganese Dioxide**Designed for Recharge:** No

Energizer has prepared copyrighted Product Safety Datasheets to provide information on the different Eveready/Energizer battery systems. Batteries are articles as defined under the GHS and exempt from GHS classification criteria (Section 1.3.2.1.1 of the GHS). The information and recommendations set forth herein are made in good faith, for information only, and are believed to be accurate as of the date of preparation. However, ENERGIZER BATTERY MANUFACTURING, INC. MAKES NO WARRANTY, EITHER EXPRESS OR IMPLIED, WITH RESPECT TO THIS INFORMATION AND DISCLAIMS ALL LIABILITY FROM REFERENCE ON IT.

SECTION 1- MANUFACTURER INFORMATION

Manufactured for
Energizer Battery Manufacturing, Inc.
25225 Detroit Rd.
Westlake, OH 44145

Telephone Number for Information:
800-383-7323 (USA / CANADA)

Date Prepared: March 2015

SECTION 2 – HAZARDS IDENTIFICATION**GHS classification:** N/A**Signal Word:** N/A**Hazard Classification:** N/A

Under normal conditions of use, the battery is hermetically sealed.

Ingestion: Swallowing may lead to serious injury or death in as little as 2 hours due to chemical burns and potential perforation of the esophagus. **Immediately see doctor; have doctor phone (202) 625-3333.** Do not induce vomiting or give food or drink.

Inhalation: Contents of an open battery can cause respiratory irritation.

Skin Contact: Contents of an open battery can cause skin irritation.

Eye Contact: Contents of an open battery can cause severe irritation.

SECTION 3 - INGREDIENTS

IMPORTANT NOTE: The battery should not be opened or burned. Exposure to the ingredients contained within or their combustion products could be harmful.

MATERIAL OR INGREDIENT	PEL (OSHA)	TLV (ACGIH)	%/wt.
Carbon Black (CAS# 1333-86-4)	3.5 mg/m ³ TWA	3.5 mg/m ³ TWA	0-1
1,2-Dimethoxyethane (CAS# 110-71-4)	None established	None established	0-6
1,3-Dioxolane (CAS# 646-06-0)	None established	None established	0-8
Graphite (CAS# 7782-42-5)	15 mg/m ³ TWA (total dust) 5 mg/m ³ TWA (respirable fraction)	2 mg/m ³ TWA (respirable fraction)	0-3
Lithium or Lithium Alloy (CAS# 7439-93-2)	None established	None established	1-6

Lithium Perchlorate (CAS# 7791-03-9)	None established	None established	0-3
Lithium Trifluoromethanesulfonate (CAS# 33454-82-9)	None established	None established	0-3
Lithium Trifluoromethanesulfonimide (CAS# 90076-65-6)	None established	None established	0-3
Manganese Dioxide (CAS# 1313-13-9)	5 mg/m ³ Ceiling (as Mn)	0.2 mg/m ³ TWA (as Mn)	12-42
Propylene Carbonate (CAS# 108-32-7)	None established	None established	0-8
Non-Hazardous Components:			
Steel (iron CAS# 65997-19-5)	None established	None established	20
Plastic and Other	None established	None established	Balance

SECTION 4 – FIRST AID MEASURES

Ingestion: Swallowing may lead to serious injury or death in as little as 2 hours due to chemical burns and potential perforation of the esophagus. **Immediately see doctor; have doctor phone (202) 625-3333.** Do not induce vomiting or give food or drink.

Inhalation: Provide fresh air and seek medical attention.

Skin Contact: Remove contaminated clothing and wash skin with soap and water.

Eye Contact: Immediately flush eyes thoroughly with water for at least 15 minutes, lifting upper and lower lids, until no evidence of the chemical remains. Seek medical attention.

Note: Carbon black is listed as a possible carcinogen by International Agency for Research on Cancer (IARC).

SECTION 5- FIRE FIGHTING MEASURES

In case of fire where lithium batteries are present, flood area with water or smother with a Class D fire extinguishant appropriate for lithium metal, such as Lith-X. Water may not extinguish burning batteries but will cool the adjacent batteries and control the spread of fire. Burning batteries will burn themselves out. Virtually all fires involving lithium batteries can be controlled by flooding with water. However, the contents of the battery will react with water and form hydrogen gas. In a confined space, hydrogen gas can form an explosive mixture. In this situation, smothering agents are recommended. A smothering agent will extinguish burning lithium batteries.

Emergency Responders should wear self-contained breathing apparatus. Burning lithium manganese dioxide batteries produce toxic and corrosive lithium hydroxide fumes.

SECTION 6 - ACCIDENTAL RELEASE MEASURES

To cleanup leaking batteries:

Ventilation Requirements: Room ventilation may be required in areas where there are open or leaking batteries.

Respiratory Protection: Avoid exposure to electrolyte fumes from open or leaking batteries.

Eye Protection: Wear safety glasses with side shields if handling an open or leaking battery.

Gloves: Use neoprene or natural rubber gloves if handling an open or leaking battery.

Battery materials should be collected in a leak-proof container.

SECTION 7 - HANDLING AND STORAGE

Storage: Store in a cool, well ventilated area. Elevated temperatures can result in shortened battery life. In locations that handle large quantities of lithium batteries, such as warehouses, lithium batteries should be isolated from unnecessary combustibles.

Mechanical Containment: If potting or sealing the battery in an airtight or watertight container is required, consult your Energizer Battery Manufacturing, Inc. representative for precautionary suggestions. Do not obstruct safety release vents on batteries. Encapsulation of batteries will not allow cell venting and can cause high pressure rupture.

Handling: Accidental short circuit for a few seconds will not seriously affect the battery. Prolonged short circuit will cause the battery to lose energy, generate significant heat and can cause the safety release vent to open. Sources of short circuits include jumbled batteries in bulk containers, metal jewelry, metal covered tables or metal belts used for assembly of batteries into devices. Damaging a lithium battery may result in an internal short circuit.

The contents of an open battery, including a vented battery, when exposed to water, may result in a fire and/or explosion. Crushed or damaged batteries may result in a fire.

If soldering or welding to the battery is required, consult your Energizer representative for proper precautions to prevent seal damage or short circuit.

Charging: This battery is manufactured in a charged state. It is not designed for recharging. Recharging can cause battery leakage or, in some cases, high pressure rupture. Inadvertent charging can occur if a battery is installed backwards.

Labeling: If the Energizer label or package warnings are not visible, it is important to provide a package and/or device label stating:

WARNING: Battery can explode or leak and cause burns if installed backwards, disassembled, charged, or exposed to water, fire or high temperature.

Where accidental ingestion of small batteries is possible, the label should include:



(1) KEEP OUT OF REACH OF CHILDREN. Swallowing may lead to serious injury or death in as little as 2 hours due to chemical burns and potential perforation of the esophagus. **Immediately see doctor; have doctor phone (202) 625-3333.** Keep in original package until ready to use. Dispose of used batteries immediately.

SECTION 8 - EXPOSURE CONTROLS/PERSONAL PROTECTION

Ventilation Requirements: Not necessary under normal conditions.

Respiratory Protection: Not necessary under normal conditions.

Eye Protection: Not necessary under normal conditions.

Gloves: Not necessary under normal conditions.

SECTION 9 – PHYSICAL AND CHEMICAL PROPERTIES

Appearance (physical state, color, etc.):	Solid object
Upper Explosive Limits:	Not applicable for an Article
Lower Explosive Limits	Not applicable for an Article
Odor	No odor
Vapor Pressure (mm Hg @ 25°C)	Not applicable for an Article
Odor Threshold	No odor
Vapor Density (Air = 1)	Not applicable for an Article
pH	Not applicable for an Article

Density (g/cm ³)	2.0-3.0
Melting point/Freezing Point	Not applicable for an Article
Solubility in Water (% by weight)	Not applicable for an Article
Boiling Point @ 760 mm Hg (°C)	Not applicable for an Article
Flash Point	Not applicable for an Article
Evaporation Rate (Butyl Acetate = 1)	Not applicable for an Article
Flammability	Not applicable for an Article
Partition Coefficient	Not applicable for an Article
Auto-ignition Temperature	Not applicable for an Article
Decomposition Temperature	Not applicable for an Article
Viscosity	Not applicable for an Article

SECTION 10 – STABILITY AND REACTIVITY

Lithium manganese dioxide batteries contain no sulfides or cyanides and they do not meet any other reactivity criteria including “reacts violently with water” and therefore do not meet any of the criteria established in 40 CFR 261.2 for reactivity.

SECTION 11 – TOXICOLOGICAL INFORMATION

Under normal conditions of use, lithium manganese dioxide batteries are non-toxic.

SECTION 12 – ECOLOGICAL INFORMATION

Issues such as ecotoxicity, persistence and bioaccumulation are not applicable for articles.

SECTION 13 – DISPOSAL CONSIDERATIONS

Lithium iron disulfide batteries are not hazardous waste per the United States Resource Conservation and Recovery Act (RCRA) - 40 CFR Part 261 Subpart C. Dispose of in accordance with all applicable federal, state and local regulations.

SECTION 14 – TRANSPORT INFORMATION

In general, all batteries in all forms of transportation (ground, air, or ocean) must be packaged in a safe and responsible manner. Regulatory concerns from all agencies for safe packaging require that batteries be packaged in a manner that prevents short circuits and be contained in “strong outer packaging” that prevents spillage of contents. All original packaging for Energizer lithium batteries are compliant with these regulatory concerns.



Energizer lithium coin batteries are exempt from the classification as dangerous goods as they meet the requirements of the special provisions listed below. (Essentially, they are properly packaged and labeled, contain less than 1 gram of lithium and pass the tests defined in UN model regulation section 38.3).

Regulatory Body	Special Provisions
ADR	188, 230, 310, 636, 656
IMDG	188, 230, 310, 957
UN	UN 3090, UN 3091
US DOT	29, A54, A100, A101
IATA, ICAO	Packaging Instructions 968 - 970

Energizer is registered with CHEMTREC. In the event of an incident during transport call 1-800-424-9300 (North America) or 1-703-527-3887 (International).

A global lithium label chart is provided below to summarize the current global labeling requirements.

Label Summary Chart

Shipping Mode	Li content	Net quantity wt. of batteries per package	Battery Type			
AIR	0.3g to \leq 1g/cell 0.3g to \leq 2g/ battery	\leq 2.5 kg	L91, L92, L522	YES	YES	YES
	\leq 0.3g/cell	\leq 2.5kg	All Li Coin and 2L76	NO	YES	YES
	\leq 0.3g/cell	>2.5kg	All Li Coin and 2L76	YES	YES	YES
Land/ Sea only	All	All	All	NO	YES	YES

SECTION 15 - REGULATORY INFORMATION

Outside of the transportation requirements noted in Section 14, lithium manganese dioxide batteries marketed by Energizer Battery Manufacturing, Inc. are not regulated.

SARA/TITLE III - As an article, this battery and its contents are not subject to the requirements of the Emergency Planning and Community Right-To-Know Act.

SECTION 16 - OTHER INFORMATION

None.

PRODUCT SAFETY DATA SHEET

PRODUCT NAME: Energizer Battery **Type No.:** **Volts:** 3.0
TRADE NAMES: Coin/Button Lithium Manganese Dioxide Batteries **Approximate Weight:** 0.6 – 7.0 g
CHEMICAL SYSTEM: Lithium Manganese Dioxide **Designed for Recharge:** No

Energizer has prepared copyrighted Product Safety Datasheets to provide information on the different Eveready/Energizer battery systems. Batteries are articles as defined under the GHS and exempt from GHS classification criteria (Section 1.3.2.1.1 of the GHS). The information and recommendations set forth herein are made in good faith, for information only, and are believed to be accurate as of the date of preparation. However, ENERGIZER BATTERY MANUFACTURING, INC. MAKES NO WARRANTY, EITHER EXPRESS OR IMPLIED, WITH RESPECT TO THIS INFORMATION AND DISCLAIMS ALL LIABILITY FROM REFERENCE ON IT.

SECTION 1- MANUFACTURER INFORMATION

Manufactured for
Energizer Battery Manufacturing, Inc.
25225 Detroit Rd.
Westlake, OH 44145

Telephone Number for Information:
800-383-7323 (USA / CANADA)

Date Prepared: March 2015

SECTION 2 – HAZARDS IDENTIFICATION

GHS classification: N/A

Signal Word: N/A

Hazard Classification: N/A

Under normal conditions of use, the battery is hermetically sealed.

Ingestion: Swallowing may lead to serious injury or death in as little as 2 hours due to chemical burns and potential perforation of the esophagus. **Immediately see doctor; have doctor phone (202) 625-3333.** Do not induce vomiting or give food or drink.

Inhalation: Contents of an open battery can cause respiratory irritation.

Skin Contact: Contents of an open battery can cause skin irritation.

Eye Contact: Contents of an open battery can cause severe irritation.

SECTION 3 - INGREDIENTS

IMPORTANT NOTE: The battery should not be opened or burned. Exposure to the ingredients contained within or their combustion products could be harmful.

MATERIAL OR INGREDIENT	PEL (OSHA)	TLV (ACGIH)	%/wt.
Carbon Black (CAS# 1333-86-4)	3.5 mg/m ³ TWA	3.5 mg/m ³ TWA	0-1
1,2-Dimethoxyethane (CAS# 110-71-4)	None established	None established	0-6
1,3-Dioxolane (CAS# 646-06-0)	None established	None established	0-8
Graphite (CAS# 7782-42-5)	15 mg/m ³ TWA (total dust) 5 mg/m ³ TWA (respirable fraction)	2 mg/m ³ TWA (respirable fraction)	0-3
Lithium or Lithium Alloy (CAS# 7439-93-2)	None established	None established	1-6

Lithium Perchlorate (CAS# 7791-03-9)	None established	None established	0-3
Lithium Trifluoromethanesulfonate (CAS# 33454-82-9)	None established	None established	0-3
Lithium Trifluoromethanesulfonimide (CAS# 90076-65-6)	None established	None established	0-3
Manganese Dioxide (CAS# 1313-13-9)	5 mg/m ³ Ceiling (as Mn)	0.2 mg/m ³ TWA (as Mn)	12-42
Propylene Carbonate (CAS# 108-32-7)	None established	None established	0-8
Non-Hazardous Components:			
Steel (iron CAS# 65997-19-5)	None established	None established	20
Plastic and Other	None established	None established	Balance

SECTION 4 – FIRST AID MEASURES

Ingestion: Swallowing may lead to serious injury or death in as little as 2 hours due to chemical burns and potential perforation of the esophagus. **Immediately see doctor; have doctor phone (202) 625-3333.** Do not induce vomiting or give food or drink.

Inhalation: Provide fresh air and seek medical attention.

Skin Contact: Remove contaminated clothing and wash skin with soap and water.

Eye Contact: Immediately flush eyes thoroughly with water for at least 15 minutes, lifting upper and lower lids, until no evidence of the chemical remains. Seek medical attention.

Note: Carbon black is listed as a possible carcinogen by International Agency for Research on Cancer (IARC).

SECTION 5- FIRE FIGHTING MEASURES

In case of fire where lithium batteries are present, flood area with water or smother with a Class D fire extinguishant appropriate for lithium metal, such as Lith-X. Water may not extinguish burning batteries but will cool the adjacent batteries and control the spread of fire. Burning batteries will burn themselves out. Virtually all fires involving lithium batteries can be controlled by flooding with water. However, the contents of the battery will react with water and form hydrogen gas. In a confined space, hydrogen gas can form an explosive mixture. In this situation, smothering agents are recommended. A smothering agent will extinguish burning lithium batteries.

Emergency Responders should wear self-contained breathing apparatus. Burning lithium manganese dioxide batteries produce toxic and corrosive lithium hydroxide fumes.

SECTION 6 - ACCIDENTAL RELEASE MEASURES

To cleanup leaking batteries:

Ventilation Requirements: Room ventilation may be required in areas where there are open or leaking batteries.

Respiratory Protection: Avoid exposure to electrolyte fumes from open or leaking batteries.

Eye Protection: Wear safety glasses with side shields if handling an open or leaking battery.

Gloves: Use neoprene or natural rubber gloves if handling an open or leaking battery.

Battery materials should be collected in a leak-proof container.

SECTION 7 - HANDLING AND STORAGE

Storage: Store in a cool, well ventilated area. Elevated temperatures can result in shortened battery life. In locations that handle large quantities of lithium batteries, such as warehouses, lithium batteries should be isolated from unnecessary combustibles.

Mechanical Containment: If potting or sealing the battery in an airtight or watertight container is required, consult your Energizer Battery Manufacturing, Inc. representative for precautionary suggestions. Do not obstruct safety release vents on batteries. Encapsulation of batteries will not allow cell venting and can cause high pressure rupture.

Handling: Accidental short circuit for a few seconds will not seriously affect the battery. Prolonged short circuit will cause the battery to lose energy, generate significant heat and can cause the safety release vent to open. Sources of short circuits include jumbled batteries in bulk containers, metal jewelry, metal covered tables or metal belts used for assembly of batteries into devices. Damaging a lithium battery may result in an internal short circuit.

The contents of an open battery, including a vented battery, when exposed to water, may result in a fire and/or explosion. Crushed or damaged batteries may result in a fire.

If soldering or welding to the battery is required, consult your Energizer representative for proper precautions to prevent seal damage or short circuit.

Charging: This battery is manufactured in a charged state. It is not designed for recharging. Recharging can cause battery leakage or, in some cases, high pressure rupture. Inadvertent charging can occur if a battery is installed backwards.

Labeling: If the Energizer label or package warnings are not visible, it is important to provide a package and/or device label stating:

WARNING: Battery can explode or leak and cause burns if installed backwards, disassembled, charged, or exposed to water, fire or high temperature.

Where accidental ingestion of small batteries is possible, the label should include:



(1) KEEP OUT OF REACH OF CHILDREN. Swallowing may lead to serious injury or death in as little as 2 hours due to chemical burns and potential perforation of the esophagus. **Immediately see doctor; have doctor phone (202) 625-3333.** Keep in original package until ready to use. Dispose of used batteries immediately.

SECTION 8 - EXPOSURE CONTROLS/PERSONAL PROTECTION

Ventilation Requirements: Not necessary under normal conditions.

Respiratory Protection: Not necessary under normal conditions.

Eye Protection: Not necessary under normal conditions.

Gloves: Not necessary under normal conditions.

SECTION 9 – PHYSICAL AND CHEMICAL PROPERTIES

Appearance (physical state, color, etc.):	Solid object
Upper Explosive Limits:	Not applicable for an Article
Lower Explosive Limits	Not applicable for an Article
Odor	No odor
Vapor Pressure (mm Hg @ 25°C)	Not applicable for an Article
Odor Threshold	No odor
Vapor Density (Air = 1)	Not applicable for an Article
pH	Not applicable for an Article

Density (g/cm ³)	2.0-3.0
Melting point/Freezing Point	Not applicable for an Article
Solubility in Water (% by weight)	Not applicable for an Article
Boiling Point @ 760 mm Hg (°C)	Not applicable for an Article
Flash Point	Not applicable for an Article
Evaporation Rate (Butyl Acetate = 1)	Not applicable for an Article
Flammability	Not applicable for an Article
Partition Coefficient	Not applicable for an Article
Auto-ignition Temperature	Not applicable for an Article
Decomposition Temperature	Not applicable for an Article
Viscosity	Not applicable for an Article

SECTION 10 – STABILITY AND REACTIVITY

Lithium manganese dioxide batteries contain no sulfides or cyanides and they do not meet any other reactivity criteria including “reacts violently with water” and therefore do not meet any of the criteria established in 40 CFR 261.2 for reactivity.

SECTION 11 – TOXICOLOGICAL INFORMATION

Under normal conditions of use, lithium manganese dioxide batteries are non-toxic.

SECTION 12 – ECOLOGICAL INFORMATION

Issues such as ecotoxicity, persistence and bioaccumulation are not applicable for articles.

SECTION 13 – DISPOSAL CONSIDERATIONS

Lithium iron disulfide batteries are not hazardous waste per the United States Resource Conservation and Recovery Act (RCRA) - 40 CFR Part 261 Subpart C. Dispose of in accordance with all applicable federal, state and local regulations.

SECTION 14 – TRANSPORT INFORMATION

In general, all batteries in all forms of transportation (ground, air, or ocean) must be packaged in a safe and responsible manner. Regulatory concerns from all agencies for safe packaging require that batteries be packaged in a manner that prevents short circuits and be contained in “strong outer packaging” that prevents spillage of contents. All original packaging for Energizer lithium batteries are compliant with these regulatory concerns.



Energizer lithium coin batteries are exempt from the classification as dangerous goods as they meet the requirements of the special provisions listed below. (Essentially, they are properly packaged and labeled, contain less than 1 gram of lithium and pass the tests defined in UN model regulation section 38.3).

Regulatory Body	Special Provisions
ADR	188, 230, 310, 636, 656
IMDG	188, 230, 310, 957
UN	UN 3090, UN 3091
US DOT	29, A54, A100, A101
IATA, ICAO	Packaging Instructions 968 - 970

Energizer is registered with CHEMTREC. In the event of an incident during transport call 1-800-424-9300 (North America) or 1-703-527-3887 (International).

A global lithium label chart is provided below to summarize the current global labeling requirements.

Label Summary Chart

Shipping Mode	Li content	Net quantity wt. of batteries per package	Battery Type			
AIR	0.3g to \leq 1g/cell 0.3g to \leq 2g/ battery	\leq 2.5 kg	L91, L92, L522	YES	YES	YES
	\leq 0.3g/cell	\leq 2.5kg	All Li Coin and 2L76	NO	YES	YES
	\leq 0.3g/cell	>2.5kg	All Li Coin and 2L76	YES	YES	YES
Land/ Sea only	All	All	All	NO	YES	YES

SECTION 15 - REGULATORY INFORMATION

Outside of the transportation requirements noted in Section 14, lithium manganese dioxide batteries marketed by Energizer Battery Manufacturing, Inc. are not regulated.

SARA/TITLE III - As an article, this battery and its contents are not subject to the requirements of the Emergency Planning and Community Right-To-Know Act.

SECTION 16 - OTHER INFORMATION

None.

PRODUCT SAFETY DATA SHEET**PRODUCT NAME:** Energizer Battery**Type No.:****Volts:** 3.0**TRADE NAMES:** Coin/Button Lithium Manganese Dioxide Batteries**Approximate Weight:** 0.6 – 7.0 g**CHEMICAL SYSTEM:** Lithium Manganese Dioxide**Designed for Recharge:** No

Energizer has prepared copyrighted Product Safety Datasheets to provide information on the different Eveready/Energizer battery systems. Batteries are articles as defined under the GHS and exempt from GHS classification criteria (Section 1.3.2.1.1 of the GHS). The information and recommendations set forth herein are made in good faith, for information only, and are believed to be accurate as of the date of preparation. However, ENERGIZER BATTERY MANUFACTURING, INC. MAKES NO WARRANTY, EITHER EXPRESS OR IMPLIED, WITH RESPECT TO THIS INFORMATION AND DISCLAIMS ALL LIABILITY FROM REFERENCE ON IT.

SECTION 1- MANUFACTURER INFORMATION

Manufactured for
Energizer Battery Manufacturing, Inc.
25225 Detroit Rd.
Westlake, OH 44145

Telephone Number for Information:
800-383-7323 (USA / CANADA)

Date Prepared: March 2015

SECTION 2 – HAZARDS IDENTIFICATION**GHS classification:** N/A**Signal Word:** N/A**Hazard Classification:** N/A

Under normal conditions of use, the battery is hermetically sealed.

Ingestion: Swallowing may lead to serious injury or death in as little as 2 hours due to chemical burns and potential perforation of the esophagus. **Immediately see doctor; have doctor phone (202) 625-3333.** Do not induce vomiting or give food or drink.

Inhalation: Contents of an open battery can cause respiratory irritation.

Skin Contact: Contents of an open battery can cause skin irritation.

Eye Contact: Contents of an open battery can cause severe irritation.

SECTION 3 - INGREDIENTS

IMPORTANT NOTE: The battery should not be opened or burned. Exposure to the ingredients contained within or their combustion products could be harmful.

MATERIAL OR INGREDIENT	PEL (OSHA)	TLV (ACGIH)	%/wt.
Carbon Black (CAS# 1333-86-4)	3.5 mg/m ³ TWA	3.5 mg/m ³ TWA	0-1
1,2-Dimethoxyethane (CAS# 110-71-4)	None established	None established	0-6
1,3-Dioxolane (CAS# 646-06-0)	None established	None established	0-8
Graphite (CAS# 7782-42-5)	15 mg/m ³ TWA (total dust) 5 mg/m ³ TWA (respirable fraction)	2 mg/m ³ TWA (respirable fraction)	0-3
Lithium or Lithium Alloy (CAS# 7439-93-2)	None established	None established	1-6

Lithium Perchlorate (CAS# 7791-03-9)	None established	None established	0-3
Lithium Trifluoromethanesulfonate (CAS# 33454-82-9)	None established	None established	0-3
Lithium Trifluoromethanesulfonimide (CAS# 90076-65-6)	None established	None established	0-3
Manganese Dioxide (CAS# 1313-13-9)	5 mg/m ³ Ceiling (as Mn)	0.2 mg/m ³ TWA (as Mn)	12-42
Propylene Carbonate (CAS# 108-32-7)	None established	None established	0-8
Non-Hazardous Components:			
Steel (iron CAS# 65997-19-5)	None established	None established	20
Plastic and Other	None established	None established	Balance

SECTION 4 – FIRST AID MEASURES

Ingestion: Swallowing may lead to serious injury or death in as little as 2 hours due to chemical burns and potential perforation of the esophagus. **Immediately see doctor; have doctor phone (202) 625-3333.** Do not induce vomiting or give food or drink.

Inhalation: Provide fresh air and seek medical attention.

Skin Contact: Remove contaminated clothing and wash skin with soap and water.

Eye Contact: Immediately flush eyes thoroughly with water for at least 15 minutes, lifting upper and lower lids, until no evidence of the chemical remains. Seek medical attention.

Note: Carbon black is listed as a possible carcinogen by International Agency for Research on Cancer (IARC).

SECTION 5- FIRE FIGHTING MEASURES

In case of fire where lithium batteries are present, flood area with water or smother with a Class D fire extinguishant appropriate for lithium metal, such as Lith-X. Water may not extinguish burning batteries but will cool the adjacent batteries and control the spread of fire. Burning batteries will burn themselves out. Virtually all fires involving lithium batteries can be controlled by flooding with water. However, the contents of the battery will react with water and form hydrogen gas. In a confined space, hydrogen gas can form an explosive mixture. In this situation, smothering agents are recommended. A smothering agent will extinguish burning lithium batteries.

Emergency Responders should wear self-contained breathing apparatus. Burning lithium manganese dioxide batteries produce toxic and corrosive lithium hydroxide fumes.

SECTION 6 - ACCIDENTAL RELEASE MEASURES

To cleanup leaking batteries:

Ventilation Requirements: Room ventilation may be required in areas where there are open or leaking batteries.

Respiratory Protection: Avoid exposure to electrolyte fumes from open or leaking batteries.

Eye Protection: Wear safety glasses with side shields if handling an open or leaking battery.

Gloves: Use neoprene or natural rubber gloves if handling an open or leaking battery.

Battery materials should be collected in a leak-proof container.

SECTION 7 - HANDLING AND STORAGE

Storage: Store in a cool, well ventilated area. Elevated temperatures can result in shortened battery life. In locations that handle large quantities of lithium batteries, such as warehouses, lithium batteries should be isolated from unnecessary combustibles.

Mechanical Containment: If potting or sealing the battery in an airtight or watertight container is required, consult your Energizer Battery Manufacturing, Inc. representative for precautionary suggestions. Do not obstruct safety release vents on batteries. Encapsulation of batteries will not allow cell venting and can cause high pressure rupture.

Handling: Accidental short circuit for a few seconds will not seriously affect the battery. Prolonged short circuit will cause the battery to lose energy, generate significant heat and can cause the safety release vent to open. Sources of short circuits include jumbled batteries in bulk containers, metal jewelry, metal covered tables or metal belts used for assembly of batteries into devices. Damaging a lithium battery may result in an internal short circuit.

The contents of an open battery, including a vented battery, when exposed to water, may result in a fire and/or explosion. Crushed or damaged batteries may result in a fire.

If soldering or welding to the battery is required, consult your Energizer representative for proper precautions to prevent seal damage or short circuit.

Charging: This battery is manufactured in a charged state. It is not designed for recharging. Recharging can cause battery leakage or, in some cases, high pressure rupture. Inadvertent charging can occur if a battery is installed backwards.

Labeling: If the Energizer label or package warnings are not visible, it is important to provide a package and/or device label stating:

WARNING: Battery can explode or leak and cause burns if installed backwards, disassembled, charged, or exposed to water, fire or high temperature.

Where accidental ingestion of small batteries is possible, the label should include:



(1) KEEP OUT OF REACH OF CHILDREN. Swallowing may lead to serious injury or death in as little as 2 hours due to chemical burns and potential perforation of the esophagus. **Immediately see doctor; have doctor phone (202) 625-3333.** Keep in original package until ready to use. Dispose of used batteries immediately.

SECTION 8 - EXPOSURE CONTROLS/PERSONAL PROTECTION

Ventilation Requirements: Not necessary under normal conditions.

Respiratory Protection: Not necessary under normal conditions.

Eye Protection: Not necessary under normal conditions.

Gloves: Not necessary under normal conditions.

SECTION 9 – PHYSICAL AND CHEMICAL PROPERTIES

Appearance (physical state, color, etc.):	Solid object
Upper Explosive Limits:	Not applicable for an Article
Lower Explosive Limits	Not applicable for an Article
Odor	No odor
Vapor Pressure (mm Hg @ 25°C)	Not applicable for an Article
Odor Threshold	No odor
Vapor Density (Air = 1)	Not applicable for an Article
pH	Not applicable for an Article

Density (g/cm ³)	2.0-3.0
Melting point/Freezing Point	Not applicable for an Article
Solubility in Water (% by weight)	Not applicable for an Article
Boiling Point @ 760 mm Hg (°C)	Not applicable for an Article
Flash Point	Not applicable for an Article
Evaporation Rate (Butyl Acetate = 1)	Not applicable for an Article
Flammability	Not applicable for an Article
Partition Coefficient	Not applicable for an Article
Auto-ignition Temperature	Not applicable for an Article
Decomposition Temperature	Not applicable for an Article
Viscosity	Not applicable for an Article

SECTION 10 – STABILITY AND REACTIVITY

Lithium manganese dioxide batteries contain no sulfides or cyanides and they do not meet any other reactivity criteria including “reacts violently with water” and therefore do not meet any of the criteria established in 40 CFR 261.2 for reactivity.

SECTION 11 – TOXICOLOGICAL INFORMATION

Under normal conditions of use, lithium manganese dioxide batteries are non-toxic.

SECTION 12 – ECOLOGICAL INFORMATION

Issues such as ecotoxicity, persistence and bioaccumulation are not applicable for articles.

SECTION 13 – DISPOSAL CONSIDERATIONS

Lithium iron disulfide batteries are not hazardous waste per the United States Resource Conservation and Recovery Act (RCRA) - 40 CFR Part 261 Subpart C. Dispose of in accordance with all applicable federal, state and local regulations.

SECTION 14 – TRANSPORT INFORMATION

In general, all batteries in all forms of transportation (ground, air, or ocean) must be packaged in a safe and responsible manner. Regulatory concerns from all agencies for safe packaging require that batteries be packaged in a manner that prevents short circuits and be contained in “strong outer packaging” that prevents spillage of contents. All original packaging for Energizer lithium batteries are compliant with these regulatory concerns.



Energizer lithium coin batteries are exempt from the classification as dangerous goods as they meet the requirements of the special provisions listed below. (Essentially, they are properly packaged and labeled, contain less than 1 gram of lithium and pass the tests defined in UN model regulation section 38.3).

Regulatory Body	Special Provisions
ADR	188, 230, 310, 636, 656
IMDG	188, 230, 310, 957
UN	UN 3090, UN 3091
US DOT	29, A54, A100, A101
IATA, ICAO	Packaging Instructions 968 - 970

Energizer is registered with CHEMTREC. In the event of an incident during transport call 1-800-424-9300 (North America) or 1-703-527-3887 (International).

A global lithium label chart is provided below to summarize the current global labeling requirements.

Label Summary Chart

Shipping Mode	Li content	Net quantity wt. of batteries per package	Battery Type			
AIR	0.3g to \leq 1g/cell 0.3g to \leq 2g/ battery	\leq 2.5 kg	L91, L92, L522	YES	YES	YES
	\leq 0.3g/cell	\leq 2.5kg	All Li Coin and 2L76	NO	YES	YES
	\leq 0.3g/cell	>2.5kg	All Li Coin and 2L76	YES	YES	YES
Land/ Sea only	All	All	All	NO	YES	YES

SECTION 15 - REGULATORY INFORMATION

Outside of the transportation requirements noted in Section 14, lithium manganese dioxide batteries marketed by Energizer Battery Manufacturing, Inc. are not regulated.

SARA/TITLE III - As an article, this battery and its contents are not subject to the requirements of the Emergency Planning and Community Right-To-Know Act.

SECTION 16 - OTHER INFORMATION

None.

PRODUCT SAFETY DATA SHEET

PRODUCT NAME: Energizer Battery **Type No.:** **Volts:** 3.0
TRADE NAMES: Coin/Button Lithium Manganese Dioxide Batteries **Approximate Weight:** 0.6 – 7.0 g
CHEMICAL SYSTEM: Lithium Manganese Dioxide **Designed for Recharge:** No

Energizer has prepared copyrighted Product Safety Datasheets to provide information on the different Eveready/Energizer battery systems. Batteries are articles as defined under the GHS and exempt from GHS classification criteria (Section 1.3.2.1.1 of the GHS). The information and recommendations set forth herein are made in good faith, for information only, and are believed to be accurate as of the date of preparation. However, ENERGIZER BATTERY MANUFACTURING, INC. MAKES NO WARRANTY, EITHER EXPRESS OR IMPLIED, WITH RESPECT TO THIS INFORMATION AND DISCLAIMS ALL LIABILITY FROM REFERENCE ON IT.

SECTION 1- MANUFACTURER INFORMATION

Manufactured for
Energizer Battery Manufacturing, Inc.
25225 Detroit Rd.
Westlake, OH 44145

Telephone Number for Information:
800-383-7323 (USA / CANADA)

Date Prepared: March 2015

SECTION 2 – HAZARDS IDENTIFICATION

GHS classification: N/A

Signal Word: N/A

Hazard Classification: N/A

Under normal conditions of use, the battery is hermetically sealed.

Ingestion: Swallowing may lead to serious injury or death in as little as 2 hours due to chemical burns and potential perforation of the esophagus. **Immediately see doctor; have doctor phone (202) 625-3333.** Do not induce vomiting or give food or drink.

Inhalation: Contents of an open battery can cause respiratory irritation.

Skin Contact: Contents of an open battery can cause skin irritation.

Eye Contact: Contents of an open battery can cause severe irritation.

SECTION 3 - INGREDIENTS

IMPORTANT NOTE: The battery should not be opened or burned. Exposure to the ingredients contained within or their combustion products could be harmful.

MATERIAL OR INGREDIENT	PEL (OSHA)	TLV (ACGIH)	%/wt.
Carbon Black (CAS# 1333-86-4)	3.5 mg/m ³ TWA	3.5 mg/m ³ TWA	0-1
1,2-Dimethoxyethane (CAS# 110-71-4)	None established	None established	0-6
1,3-Dioxolane (CAS# 646-06-0)	None established	None established	0-8
Graphite (CAS# 7782-42-5)	15 mg/m ³ TWA (total dust) 5 mg/m ³ TWA (respirable fraction)	2 mg/m ³ TWA (respirable fraction)	0-3
Lithium or Lithium Alloy (CAS# 7439-93-2)	None established	None established	1-6

Lithium Perchlorate (CAS# 7791-03-9)	None established	None established	0-3
Lithium Trifluoromethanesulfonate (CAS# 33454-82-9)	None established	None established	0-3
Lithium Trifluoromethanesulfonimide (CAS# 90076-65-6)	None established	None established	0-3
Manganese Dioxide (CAS# 1313-13-9)	5 mg/m ³ Ceiling (as Mn)	0.2 mg/m ³ TWA (as Mn)	12-42
Propylene Carbonate (CAS# 108-32-7)	None established	None established	0-8
Non-Hazardous Components:			
Steel (iron CAS# 65997-19-5)	None established	None established	20
Plastic and Other	None established	None established	Balance

SECTION 4 – FIRST AID MEASURES

Ingestion: Swallowing may lead to serious injury or death in as little as 2 hours due to chemical burns and potential perforation of the esophagus. **Immediately see doctor; have doctor phone (202) 625-3333.** Do not induce vomiting or give food or drink.

Inhalation: Provide fresh air and seek medical attention.

Skin Contact: Remove contaminated clothing and wash skin with soap and water.

Eye Contact: Immediately flush eyes thoroughly with water for at least 15 minutes, lifting upper and lower lids, until no evidence of the chemical remains. Seek medical attention.

Note: Carbon black is listed as a possible carcinogen by International Agency for Research on Cancer (IARC).

SECTION 5- FIRE FIGHTING MEASURES

In case of fire where lithium batteries are present, flood area with water or smother with a Class D fire extinguishant appropriate for lithium metal, such as Lith-X. Water may not extinguish burning batteries but will cool the adjacent batteries and control the spread of fire. Burning batteries will burn themselves out. Virtually all fires involving lithium batteries can be controlled by flooding with water. However, the contents of the battery will react with water and form hydrogen gas. In a confined space, hydrogen gas can form an explosive mixture. In this situation, smothering agents are recommended. A smothering agent will extinguish burning lithium batteries.

Emergency Responders should wear self-contained breathing apparatus. Burning lithium manganese dioxide batteries produce toxic and corrosive lithium hydroxide fumes.

SECTION 6 - ACCIDENTAL RELEASE MEASURES

To cleanup leaking batteries:

Ventilation Requirements: Room ventilation may be required in areas where there are open or leaking batteries.

Respiratory Protection: Avoid exposure to electrolyte fumes from open or leaking batteries.

Eye Protection: Wear safety glasses with side shields if handling an open or leaking battery.

Gloves: Use neoprene or natural rubber gloves if handling an open or leaking battery.

Battery materials should be collected in a leak-proof container.

SECTION 7 - HANDLING AND STORAGE

Storage: Store in a cool, well ventilated area. Elevated temperatures can result in shortened battery life. In locations that handle large quantities of lithium batteries, such as warehouses, lithium batteries should be isolated from unnecessary combustibles.

Mechanical Containment: If potting or sealing the battery in an airtight or watertight container is required, consult your Energizer Battery Manufacturing, Inc. representative for precautionary suggestions. Do not obstruct safety release vents on batteries. Encapsulation of batteries will not allow cell venting and can cause high pressure rupture.

Handling: Accidental short circuit for a few seconds will not seriously affect the battery. Prolonged short circuit will cause the battery to lose energy, generate significant heat and can cause the safety release vent to open. Sources of short circuits include jumbled batteries in bulk containers, metal jewelry, metal covered tables or metal belts used for assembly of batteries into devices. Damaging a lithium battery may result in an internal short circuit.

The contents of an open battery, including a vented battery, when exposed to water, may result in a fire and/or explosion. Crushed or damaged batteries may result in a fire.

If soldering or welding to the battery is required, consult your Energizer representative for proper precautions to prevent seal damage or short circuit.

Charging: This battery is manufactured in a charged state. It is not designed for recharging. Recharging can cause battery leakage or, in some cases, high pressure rupture. Inadvertent charging can occur if a battery is installed backwards.

Labeling: If the Energizer label or package warnings are not visible, it is important to provide a package and/or device label stating:

WARNING: Battery can explode or leak and cause burns if installed backwards, disassembled, charged, or exposed to water, fire or high temperature.

Where accidental ingestion of small batteries is possible, the label should include:



(1) KEEP OUT OF REACH OF CHILDREN. Swallowing may lead to serious injury or death in as little as 2 hours due to chemical burns and potential perforation of the esophagus. **Immediately see doctor; have doctor phone (202) 625-3333.** Keep in original package until ready to use. Dispose of used batteries immediately.

SECTION 8 - EXPOSURE CONTROLS/PERSONAL PROTECTION

Ventilation Requirements: Not necessary under normal conditions.

Respiratory Protection: Not necessary under normal conditions.

Eye Protection: Not necessary under normal conditions.

Gloves: Not necessary under normal conditions.

SECTION 9 – PHYSICAL AND CHEMICAL PROPERTIES

Appearance (physical state, color, etc.):	Solid object
Upper Explosive Limits:	Not applicable for an Article
Lower Explosive Limits	Not applicable for an Article
Odor	No odor
Vapor Pressure (mm Hg @ 25°C)	Not applicable for an Article
Odor Threshold	No odor
Vapor Density (Air = 1)	Not applicable for an Article
pH	Not applicable for an Article

Density (g/cm ³)	2.0-3.0
Melting point/Freezing Point	Not applicable for an Article
Solubility in Water (% by weight)	Not applicable for an Article
Boiling Point @ 760 mm Hg (°C)	Not applicable for an Article
Flash Point	Not applicable for an Article
Evaporation Rate (Butyl Acetate = 1)	Not applicable for an Article
Flammability	Not applicable for an Article
Partition Coefficient	Not applicable for an Article
Auto-ignition Temperature	Not applicable for an Article
Decomposition Temperature	Not applicable for an Article
Viscosity	Not applicable for an Article

SECTION 10 – STABILITY AND REACTIVITY

Lithium manganese dioxide batteries contain no sulfides or cyanides and they do not meet any other reactivity criteria including “reacts violently with water” and therefore do not meet any of the criteria established in 40 CFR 261.2 for reactivity.

SECTION 11 – TOXICOLOGICAL INFORMATION

Under normal conditions of use, lithium manganese dioxide batteries are non-toxic.

SECTION 12 – ECOLOGICAL INFORMATION

Issues such as ecotoxicity, persistence and bioaccumulation are not applicable for articles.

SECTION 13 – DISPOSAL CONSIDERATIONS

Lithium iron disulfide batteries are not hazardous waste per the United States Resource Conservation and Recovery Act (RCRA) - 40 CFR Part 261 Subpart C. Dispose of in accordance with all applicable federal, state and local regulations.

SECTION 14 – TRANSPORT INFORMATION

In general, all batteries in all forms of transportation (ground, air, or ocean) must be packaged in a safe and responsible manner. Regulatory concerns from all agencies for safe packaging require that batteries be packaged in a manner that prevents short circuits and be contained in “strong outer packaging” that prevents spillage of contents. All original packaging for Energizer lithium batteries are compliant with these regulatory concerns.



Energizer lithium coin batteries are exempt from the classification as dangerous goods as they meet the requirements of the special provisions listed below. (Essentially, they are properly packaged and labeled, contain less than 1 gram of lithium and pass the tests defined in UN model regulation section 38.3).

Regulatory Body	Special Provisions
ADR	188, 230, 310, 636, 656
IMDG	188, 230, 310, 957
UN	UN 3090, UN 3091
US DOT	29, A54, A100, A101
IATA, ICAO	Packaging Instructions 968 - 970

Energizer is registered with CHEMTREC. In the event of an incident during transport call 1-800-424-9300 (North America) or 1-703-527-3887 (International).

A global lithium label chart is provided below to summarize the current global labeling requirements.

Label Summary Chart

Shipping Mode	Li content	Net quantity wt. of batteries per package	Battery Type			
AIR	0.3g to ≤ 1 g/cell 0.3g to ≤ 2 g/ battery	≤ 2.5 kg	L91, L92, L522	YES	YES	YES
	≤ 0.3 g/cell	≤ 2.5 kg	All Li Coin and 2L76	NO	YES	YES
	≤ 0.3 g/cell	> 2.5 kg	All Li Coin and 2L76	YES	YES	YES
Land/ Sea only	All	All	All	NO	YES	YES

SECTION 15 - REGULATORY INFORMATION

Outside of the transportation requirements noted in Section 14, lithium manganese dioxide batteries marketed by Energizer Battery Manufacturing, Inc. are not regulated.

SARA/TITLE III - As an article, this battery and its contents are not subject to the requirements of the Emergency Planning and Community Right-To-Know Act.

SECTION 16 - OTHER INFORMATION

None.

PRODUCT SAFETY DATA SHEET**PRODUCT NAME:** Energizer Battery**Type No.:****Volts:** 3.0**TRADE NAMES:** Coin/Button Lithium Manganese Dioxide Batteries**Approximate Weight:** 0.6 – 7.0 g**CHEMICAL SYSTEM:** Lithium Manganese Dioxide**Designed for Recharge:** No

Energizer has prepared copyrighted Product Safety Datasheets to provide information on the different Eveready/Energizer battery systems. Batteries are articles as defined under the GHS and exempt from GHS classification criteria (Section 1.3.2.1.1 of the GHS). The information and recommendations set forth herein are made in good faith, for information only, and are believed to be accurate as of the date of preparation. However, ENERGIZER BATTERY MANUFACTURING, INC. MAKES NO WARRANTY, EITHER EXPRESS OR IMPLIED, WITH RESPECT TO THIS INFORMATION AND DISCLAIMS ALL LIABILITY FROM REFERENCE ON IT.

SECTION 1- MANUFACTURER INFORMATION

Manufactured for
Energizer Battery Manufacturing, Inc.
25225 Detroit Rd.
Westlake, OH 44145

Telephone Number for Information:
800-383-7323 (USA / CANADA)

Date Prepared: March 2015

SECTION 2 – HAZARDS IDENTIFICATION**GHS classification:** N/A**Signal Word:** N/A**Hazard Classification:** N/A

Under normal conditions of use, the battery is hermetically sealed.

Ingestion: Swallowing may lead to serious injury or death in as little as 2 hours due to chemical burns and potential perforation of the esophagus. **Immediately see doctor; have doctor phone (202) 625-3333.** Do not induce vomiting or give food or drink.

Inhalation: Contents of an open battery can cause respiratory irritation.

Skin Contact: Contents of an open battery can cause skin irritation.

Eye Contact: Contents of an open battery can cause severe irritation.

SECTION 3 - INGREDIENTS

IMPORTANT NOTE: The battery should not be opened or burned. Exposure to the ingredients contained within or their combustion products could be harmful.

MATERIAL OR INGREDIENT	PEL (OSHA)	TLV (ACGIH)	%/wt.
Carbon Black (CAS# 1333-86-4)	3.5 mg/m ³ TWA	3.5 mg/m ³ TWA	0-1
1,2-Dimethoxyethane (CAS# 110-71-4)	None established	None established	0-6
1,3-Dioxolane (CAS# 646-06-0)	None established	None established	0-8
Graphite (CAS# 7782-42-5)	15 mg/m ³ TWA (total dust) 5 mg/m ³ TWA (respirable fraction)	2 mg/m ³ TWA (respirable fraction)	0-3
Lithium or Lithium Alloy (CAS# 7439-93-2)	None established	None established	1-6

Lithium Perchlorate (CAS# 7791-03-9)	None established	None established	0-3
Lithium Trifluoromethanesulfonate (CAS# 33454-82-9)	None established	None established	0-3
Lithium Trifluoromethanesulfonimide (CAS# 90076-65-6)	None established	None established	0-3
Manganese Dioxide (CAS# 1313-13-9)	5 mg/m ³ Ceiling (as Mn)	0.2 mg/m ³ TWA (as Mn)	12-42
Propylene Carbonate (CAS# 108-32-7)	None established	None established	0-8
Non-Hazardous Components:			
Steel (iron CAS# 65997-19-5)	None established	None established	20
Plastic and Other	None established	None established	Balance

SECTION 4 – FIRST AID MEASURES

Ingestion: Swallowing may lead to serious injury or death in as little as 2 hours due to chemical burns and potential perforation of the esophagus. **Immediately see doctor; have doctor phone (202) 625-3333.** Do not induce vomiting or give food or drink.

Inhalation: Provide fresh air and seek medical attention.

Skin Contact: Remove contaminated clothing and wash skin with soap and water.

Eye Contact: Immediately flush eyes thoroughly with water for at least 15 minutes, lifting upper and lower lids, until no evidence of the chemical remains. Seek medical attention.

Note: Carbon black is listed as a possible carcinogen by International Agency for Research on Cancer (IARC).

SECTION 5- FIRE FIGHTING MEASURES

In case of fire where lithium batteries are present, flood area with water or smother with a Class D fire extinguishant appropriate for lithium metal, such as Lith-X. Water may not extinguish burning batteries but will cool the adjacent batteries and control the spread of fire. Burning batteries will burn themselves out. Virtually all fires involving lithium batteries can be controlled by flooding with water. However, the contents of the battery will react with water and form hydrogen gas. In a confined space, hydrogen gas can form an explosive mixture. In this situation, smothering agents are recommended. A smothering agent will extinguish burning lithium batteries.

Emergency Responders should wear self-contained breathing apparatus. Burning lithium manganese dioxide batteries produce toxic and corrosive lithium hydroxide fumes.

SECTION 6 - ACCIDENTAL RELEASE MEASURES

To cleanup leaking batteries:

Ventilation Requirements: Room ventilation may be required in areas where there are open or leaking batteries.

Respiratory Protection: Avoid exposure to electrolyte fumes from open or leaking batteries.

Eye Protection: Wear safety glasses with side shields if handling an open or leaking battery.

Gloves: Use neoprene or natural rubber gloves if handling an open or leaking battery.

Battery materials should be collected in a leak-proof container.

SECTION 7 - HANDLING AND STORAGE

Storage: Store in a cool, well ventilated area. Elevated temperatures can result in shortened battery life. In locations that handle large quantities of lithium batteries, such as warehouses, lithium batteries should be isolated from unnecessary combustibles.

Mechanical Containment: If potting or sealing the battery in an airtight or watertight container is required, consult your Energizer Battery Manufacturing, Inc. representative for precautionary suggestions. Do not obstruct safety release vents on batteries. Encapsulation of batteries will not allow cell venting and can cause high pressure rupture.

Handling: Accidental short circuit for a few seconds will not seriously affect the battery. Prolonged short circuit will cause the battery to lose energy, generate significant heat and can cause the safety release vent to open. Sources of short circuits include jumbled batteries in bulk containers, metal jewelry, metal covered tables or metal belts used for assembly of batteries into devices. Damaging a lithium battery may result in an internal short circuit.

The contents of an open battery, including a vented battery, when exposed to water, may result in a fire and/or explosion. Crushed or damaged batteries may result in a fire.

If soldering or welding to the battery is required, consult your Energizer representative for proper precautions to prevent seal damage or short circuit.

Charging: This battery is manufactured in a charged state. It is not designed for recharging. Recharging can cause battery leakage or, in some cases, high pressure rupture. Inadvertent charging can occur if a battery is installed backwards.

Labeling: If the Energizer label or package warnings are not visible, it is important to provide a package and/or device label stating:

WARNING: Battery can explode or leak and cause burns if installed backwards, disassembled, charged, or exposed to water, fire or high temperature.

Where accidental ingestion of small batteries is possible, the label should include:



(1) KEEP OUT OF REACH OF CHILDREN. Swallowing may lead to serious injury or death in as little as 2 hours due to chemical burns and potential perforation of the esophagus. **Immediately see doctor; have doctor phone (202) 625-3333.** Keep in original package until ready to use. Dispose of used batteries immediately.

SECTION 8 - EXPOSURE CONTROLS/PERSONAL PROTECTION

Ventilation Requirements: Not necessary under normal conditions.

Respiratory Protection: Not necessary under normal conditions.

Eye Protection: Not necessary under normal conditions.

Gloves: Not necessary under normal conditions.

SECTION 9 – PHYSICAL AND CHEMICAL PROPERTIES

Appearance (physical state, color, etc.):	Solid object
Upper Explosive Limits:	Not applicable for an Article
Lower Explosive Limits	Not applicable for an Article
Odor	No odor
Vapor Pressure (mm Hg @ 25°C)	Not applicable for an Article
Odor Threshold	No odor
Vapor Density (Air = 1)	Not applicable for an Article
pH	Not applicable for an Article

Density (g/cm ³)	2.0-3.0
Melting point/Freezing Point	Not applicable for an Article
Solubility in Water (% by weight)	Not applicable for an Article
Boiling Point @ 760 mm Hg (°C)	Not applicable for an Article
Flash Point	Not applicable for an Article
Evaporation Rate (Butyl Acetate = 1)	Not applicable for an Article
Flammability	Not applicable for an Article
Partition Coefficient	Not applicable for an Article
Auto-ignition Temperature	Not applicable for an Article
Decomposition Temperature	Not applicable for an Article
Viscosity	Not applicable for an Article

SECTION 10 – STABILITY AND REACTIVITY

Lithium manganese dioxide batteries contain no sulfides or cyanides and they do not meet any other reactivity criteria including “reacts violently with water” and therefore do not meet any of the criteria established in 40 CFR 261.2 for reactivity.

SECTION 11 – TOXICOLOGICAL INFORMATION

Under normal conditions of use, lithium manganese dioxide batteries are non-toxic.

SECTION 12 – ECOLOGICAL INFORMATION

Issues such as ecotoxicity, persistence and bioaccumulation are not applicable for articles.

SECTION 13 – DISPOSAL CONSIDERATIONS

Lithium iron disulfide batteries are not hazardous waste per the United States Resource Conservation and Recovery Act (RCRA) - 40 CFR Part 261 Subpart C. Dispose of in accordance with all applicable federal, state and local regulations.

SECTION 14 – TRANSPORT INFORMATION

In general, all batteries in all forms of transportation (ground, air, or ocean) must be packaged in a safe and responsible manner. Regulatory concerns from all agencies for safe packaging require that batteries be packaged in a manner that prevents short circuits and be contained in “strong outer packaging” that prevents spillage of contents. All original packaging for Energizer lithium batteries are compliant with these regulatory concerns.



Energizer lithium coin batteries are exempt from the classification as dangerous goods as they meet the requirements of the special provisions listed below. (Essentially, they are properly packaged and labeled, contain less than 1 gram of lithium and pass the tests defined in UN model regulation section 38.3).

Regulatory Body	Special Provisions
ADR	188, 230, 310, 636, 656
IMDG	188, 230, 310, 957
UN	UN 3090, UN 3091
US DOT	29, A54, A100, A101
IATA, ICAO	Packaging Instructions 968 - 970

Energizer is registered with CHEMTREC. In the event of an incident during transport call 1-800-424-9300 (North America) or 1-703-527-3887 (International).

A global lithium label chart is provided below to summarize the current global labeling requirements.

Label Summary Chart

Shipping Mode	Li content	Net quantity wt. of batteries per package	Battery Type			
AIR	0.3g to \leq 1g/cell 0.3g to \leq 2g/ battery	\leq 2.5 kg	L91, L92, L522	YES	YES	YES
	\leq 0.3g/cell	\leq 2.5kg	All Li Coin and 2L76	NO	YES	YES
	\leq 0.3g/cell	>2.5kg	All Li Coin and 2L76	YES	YES	YES
Land/ Sea only	All	All	All	NO	YES	YES

SECTION 15 - REGULATORY INFORMATION

Outside of the transportation requirements noted in Section 14, lithium manganese dioxide batteries marketed by Energizer Battery Manufacturing, Inc. are not regulated.

SARA/TITLE III - As an article, this battery and its contents are not subject to the requirements of the Emergency Planning and Community Right-To-Know Act.

SECTION 16 - OTHER INFORMATION

None.

PRODUCT SAFETY DATA SHEET**PRODUCT NAME:** Energizer Battery**Type No.:****Volts:** 3.0**TRADE NAMES:** Coin/Button Lithium Manganese Dioxide Batteries**Approximate Weight:** 0.6 – 7.0 g**CHEMICAL SYSTEM:** Lithium Manganese Dioxide**Designed for Recharge:** No

Energizer has prepared copyrighted Product Safety Datasheets to provide information on the different Eveready/Energizer battery systems. Batteries are articles as defined under the GHS and exempt from GHS classification criteria (Section 1.3.2.1.1 of the GHS). The information and recommendations set forth herein are made in good faith, for information only, and are believed to be accurate as of the date of preparation. However, ENERGIZER BATTERY MANUFACTURING, INC. MAKES NO WARRANTY, EITHER EXPRESS OR IMPLIED, WITH RESPECT TO THIS INFORMATION AND DISCLAIMS ALL LIABILITY FROM REFERENCE ON IT.

SECTION 1- MANUFACTURER INFORMATION

Manufactured for
Energizer Battery Manufacturing, Inc.
25225 Detroit Rd.
Westlake, OH 44145

Telephone Number for Information:
800-383-7323 (USA / CANADA)

Date Prepared: March 2015

SECTION 2 – HAZARDS IDENTIFICATION**GHS classification:** N/A**Signal Word:** N/A**Hazard Classification:** N/A

Under normal conditions of use, the battery is hermetically sealed.

Ingestion: Swallowing may lead to serious injury or death in as little as 2 hours due to chemical burns and potential perforation of the esophagus. **Immediately see doctor; have doctor phone (202) 625-3333.** Do not induce vomiting or give food or drink.

Inhalation: Contents of an open battery can cause respiratory irritation.

Skin Contact: Contents of an open battery can cause skin irritation.

Eye Contact: Contents of an open battery can cause severe irritation.

SECTION 3 - INGREDIENTS

IMPORTANT NOTE: The battery should not be opened or burned. Exposure to the ingredients contained within or their combustion products could be harmful.

MATERIAL OR INGREDIENT	PEL (OSHA)	TLV (ACGIH)	%/wt.
Carbon Black (CAS# 1333-86-4)	3.5 mg/m ³ TWA	3.5 mg/m ³ TWA	0-1
1,2-Dimethoxyethane (CAS# 110-71-4)	None established	None established	0-6
1,3-Dioxolane (CAS# 646-06-0)	None established	None established	0-8
Graphite (CAS# 7782-42-5)	15 mg/m ³ TWA (total dust) 5 mg/m ³ TWA (respirable fraction)	2 mg/m ³ TWA (respirable fraction)	0-3
Lithium or Lithium Alloy (CAS# 7439-93-2)	None established	None established	1-6

Lithium Perchlorate (CAS# 7791-03-9)	None established	None established	0-3
Lithium Trifluoromethanesulfonate (CAS# 33454-82-9)	None established	None established	0-3
Lithium Trifluoromethanesulfonimide (CAS# 90076-65-6)	None established	None established	0-3
Manganese Dioxide (CAS# 1313-13-9)	5 mg/m ³ Ceiling (as Mn)	0.2 mg/m ³ TWA (as Mn)	12-42
Propylene Carbonate (CAS# 108-32-7)	None established	None established	0-8
Non-Hazardous Components:			
Steel (iron CAS# 65997-19-5)	None established	None established	20
Plastic and Other	None established	None established	Balance

SECTION 4 – FIRST AID MEASURES

Ingestion: Swallowing may lead to serious injury or death in as little as 2 hours due to chemical burns and potential perforation of the esophagus. **Immediately see doctor; have doctor phone (202) 625-3333.** Do not induce vomiting or give food or drink.

Inhalation: Provide fresh air and seek medical attention.

Skin Contact: Remove contaminated clothing and wash skin with soap and water.

Eye Contact: Immediately flush eyes thoroughly with water for at least 15 minutes, lifting upper and lower lids, until no evidence of the chemical remains. Seek medical attention.

Note: Carbon black is listed as a possible carcinogen by International Agency for Research on Cancer (IARC).

SECTION 5- FIRE FIGHTING MEASURES

In case of fire where lithium batteries are present, flood area with water or smother with a Class D fire extinguishant appropriate for lithium metal, such as Lith-X. Water may not extinguish burning batteries but will cool the adjacent batteries and control the spread of fire. Burning batteries will burn themselves out. Virtually all fires involving lithium batteries can be controlled by flooding with water. However, the contents of the battery will react with water and form hydrogen gas. In a confined space, hydrogen gas can form an explosive mixture. In this situation, smothering agents are recommended. A smothering agent will extinguish burning lithium batteries.

Emergency Responders should wear self-contained breathing apparatus. Burning lithium manganese dioxide batteries produce toxic and corrosive lithium hydroxide fumes.

SECTION 6 - ACCIDENTAL RELEASE MEASURES

To cleanup leaking batteries:

Ventilation Requirements: Room ventilation may be required in areas where there are open or leaking batteries.

Respiratory Protection: Avoid exposure to electrolyte fumes from open or leaking batteries.

Eye Protection: Wear safety glasses with side shields if handling an open or leaking battery.

Gloves: Use neoprene or natural rubber gloves if handling an open or leaking battery.

Battery materials should be collected in a leak-proof container.

SECTION 7 - HANDLING AND STORAGE

Storage: Store in a cool, well ventilated area. Elevated temperatures can result in shortened battery life. In locations that handle large quantities of lithium batteries, such as warehouses, lithium batteries should be isolated from unnecessary combustibles.

Mechanical Containment: If potting or sealing the battery in an airtight or watertight container is required, consult your Energizer Battery Manufacturing, Inc. representative for precautionary suggestions. Do not obstruct safety release vents on batteries. Encapsulation of batteries will not allow cell venting and can cause high pressure rupture.

Handling: Accidental short circuit for a few seconds will not seriously affect the battery. Prolonged short circuit will cause the battery to lose energy, generate significant heat and can cause the safety release vent to open. Sources of short circuits include jumbled batteries in bulk containers, metal jewelry, metal covered tables or metal belts used for assembly of batteries into devices. Damaging a lithium battery may result in an internal short circuit.

The contents of an open battery, including a vented battery, when exposed to water, may result in a fire and/or explosion. Crushed or damaged batteries may result in a fire.

If soldering or welding to the battery is required, consult your Energizer representative for proper precautions to prevent seal damage or short circuit.

Charging: This battery is manufactured in a charged state. It is not designed for recharging. Recharging can cause battery leakage or, in some cases, high pressure rupture. Inadvertent charging can occur if a battery is installed backwards.

Labeling: If the Energizer label or package warnings are not visible, it is important to provide a package and/or device label stating:

WARNING: Battery can explode or leak and cause burns if installed backwards, disassembled, charged, or exposed to water, fire or high temperature.

Where accidental ingestion of small batteries is possible, the label should include:



(1) KEEP OUT OF REACH OF CHILDREN. Swallowing may lead to serious injury or death in as little as 2 hours due to chemical burns and potential perforation of the esophagus. **Immediately see doctor; have doctor phone (202) 625-3333.** Keep in original package until ready to use. Dispose of used batteries immediately.

SECTION 8 - EXPOSURE CONTROLS/PERSONAL PROTECTION

Ventilation Requirements: Not necessary under normal conditions.

Respiratory Protection: Not necessary under normal conditions.

Eye Protection: Not necessary under normal conditions.

Gloves: Not necessary under normal conditions.

SECTION 9 – PHYSICAL AND CHEMICAL PROPERTIES

Appearance (physical state, color, etc.):	Solid object
Upper Explosive Limits:	Not applicable for an Article
Lower Explosive Limits	Not applicable for an Article
Odor	No odor
Vapor Pressure (mm Hg @ 25°C)	Not applicable for an Article
Odor Threshold	No odor
Vapor Density (Air = 1)	Not applicable for an Article
pH	Not applicable for an Article

Density (g/cm ³)	2.0-3.0
Melting point/Freezing Point	Not applicable for an Article
Solubility in Water (% by weight)	Not applicable for an Article
Boiling Point @ 760 mm Hg (°C)	Not applicable for an Article
Flash Point	Not applicable for an Article
Evaporation Rate (Butyl Acetate = 1)	Not applicable for an Article
Flammability	Not applicable for an Article
Partition Coefficient	Not applicable for an Article
Auto-ignition Temperature	Not applicable for an Article
Decomposition Temperature	Not applicable for an Article
Viscosity	Not applicable for an Article

SECTION 10 – STABILITY AND REACTIVITY

Lithium manganese dioxide batteries contain no sulfides or cyanides and they do not meet any other reactivity criteria including “reacts violently with water” and therefore do not meet any of the criteria established in 40 CFR 261.2 for reactivity.

SECTION 11 – TOXICOLOGICAL INFORMATION

Under normal conditions of use, lithium manganese dioxide batteries are non-toxic.

SECTION 12 – ECOLOGICAL INFORMATION

Issues such as ecotoxicity, persistence and bioaccumulation are not applicable for articles.

SECTION 13 – DISPOSAL CONSIDERATIONS

Lithium iron disulfide batteries are not hazardous waste per the United States Resource Conservation and Recovery Act (RCRA) - 40 CFR Part 261 Subpart C. Dispose of in accordance with all applicable federal, state and local regulations.

SECTION 14 – TRANSPORT INFORMATION

In general, all batteries in all forms of transportation (ground, air, or ocean) must be packaged in a safe and responsible manner. Regulatory concerns from all agencies for safe packaging require that batteries be packaged in a manner that prevents short circuits and be contained in “strong outer packaging” that prevents spillage of contents. All original packaging for Energizer lithium batteries are compliant with these regulatory concerns.



Energizer lithium coin batteries are exempt from the classification as dangerous goods as they meet the requirements of the special provisions listed below. (Essentially, they are properly packaged and labeled, contain less than 1 gram of lithium and pass the tests defined in UN model regulation section 38.3).

Regulatory Body	Special Provisions
ADR	188, 230, 310, 636, 656
IMDG	188, 230, 310, 957
UN	UN 3090, UN 3091
US DOT	29, A54, A100, A101
IATA, ICAO	Packaging Instructions 968 - 970

Energizer is registered with CHEMTREC. In the event of an incident during transport call 1-800-424-9300 (North America) or 1-703-527-3887 (International).

A global lithium label chart is provided below to summarize the current global labeling requirements.

Label Summary Chart

Shipping Mode	Li content	Net quantity wt. of batteries per package	Battery Type			
AIR	0.3g to ≤ 1 g/cell 0.3g to ≤ 2 g/ battery	≤ 2.5 kg	L91, L92, L522	YES	YES	YES
	≤ 0.3 g/cell	≤ 2.5 kg	All Li Coin and 2L76	NO	YES	YES
	≤ 0.3 g/cell	> 2.5 kg	All Li Coin and 2L76	YES	YES	YES
Land/ Sea only	All	All	All	NO	YES	YES

SECTION 15 - REGULATORY INFORMATION

Outside of the transportation requirements noted in Section 14, lithium manganese dioxide batteries marketed by Energizer Battery Manufacturing, Inc. are not regulated.

SARA/TITLE III - As an article, this battery and its contents are not subject to the requirements of the Emergency Planning and Community Right-To-Know Act.

SECTION 16 - OTHER INFORMATION

None.

PRODUCT SAFETY DATA SHEET

PRODUCT NAME: Energizer Battery **Type No.:** **Volts:** 3.0
TRADE NAMES: Coin/Button Lithium Manganese Dioxide Batteries **Approximate Weight:** 0.6 – 7.0 g
CHEMICAL SYSTEM: Lithium Manganese Dioxide **Designed for Recharge:** No

Energizer has prepared copyrighted Product Safety Datasheets to provide information on the different Eveready/Energizer battery systems. Batteries are articles as defined under the GHS and exempt from GHS classification criteria (Section 1.3.2.1.1 of the GHS). The information and recommendations set forth herein are made in good faith, for information only, and are believed to be accurate as of the date of preparation. However, ENERGIZER BATTERY MANUFACTURING, INC. MAKES NO WARRANTY, EITHER EXPRESS OR IMPLIED, WITH RESPECT TO THIS INFORMATION AND DISCLAIMS ALL LIABILITY FROM REFERENCE ON IT.

SECTION 1- MANUFACTURER INFORMATION

Manufactured for
Energizer Battery Manufacturing, Inc.
25225 Detroit Rd.
Westlake, OH 44145

Telephone Number for Information:
800-383-7323 (USA / CANADA)

Date Prepared: March 2015

SECTION 2 – HAZARDS IDENTIFICATION

GHS classification: N/A

Signal Word: N/A

Hazard Classification: N/A

Under normal conditions of use, the battery is hermetically sealed.

Ingestion: Swallowing may lead to serious injury or death in as little as 2 hours due to chemical burns and potential perforation of the esophagus. **Immediately see doctor; have doctor phone (202) 625-3333.** Do not induce vomiting or give food or drink.

Inhalation: Contents of an open battery can cause respiratory irritation.

Skin Contact: Contents of an open battery can cause skin irritation.

Eye Contact: Contents of an open battery can cause severe irritation.

SECTION 3 - INGREDIENTS

IMPORTANT NOTE: The battery should not be opened or burned. Exposure to the ingredients contained within or their combustion products could be harmful.

MATERIAL OR INGREDIENT	PEL (OSHA)	TLV (ACGIH)	%/wt.
Carbon Black (CAS# 1333-86-4)	3.5 mg/m ³ TWA	3.5 mg/m ³ TWA	0-1
1,2-Dimethoxyethane (CAS# 110-71-4)	None established	None established	0-6
1,3-Dioxolane (CAS# 646-06-0)	None established	None established	0-8
Graphite (CAS# 7782-42-5)	15 mg/m ³ TWA (total dust) 5 mg/m ³ TWA (respirable fraction)	2 mg/m ³ TWA (respirable fraction)	0-3
Lithium or Lithium Alloy (CAS# 7439-93-2)	None established	None established	1-6

Lithium Perchlorate (CAS# 7791-03-9)	None established	None established	0-3
Lithium Trifluoromethanesulfonate (CAS# 33454-82-9)	None established	None established	0-3
Lithium Trifluoromethanesulfonimide (CAS# 90076-65-6)	None established	None established	0-3
Manganese Dioxide (CAS# 1313-13-9)	5 mg/m ³ Ceiling (as Mn)	0.2 mg/m ³ TWA (as Mn)	12-42
Propylene Carbonate (CAS# 108-32-7)	None established	None established	0-8
Non-Hazardous Components:			
Steel (iron CAS# 65997-19-5)	None established	None established	20
Plastic and Other	None established	None established	Balance

SECTION 4 – FIRST AID MEASURES

Ingestion: Swallowing may lead to serious injury or death in as little as 2 hours due to chemical burns and potential perforation of the esophagus. **Immediately see doctor; have doctor phone (202) 625-3333.** Do not induce vomiting or give food or drink.

Inhalation: Provide fresh air and seek medical attention.

Skin Contact: Remove contaminated clothing and wash skin with soap and water.

Eye Contact: Immediately flush eyes thoroughly with water for at least 15 minutes, lifting upper and lower lids, until no evidence of the chemical remains. Seek medical attention.

Note: Carbon black is listed as a possible carcinogen by International Agency for Research on Cancer (IARC).

SECTION 5- FIRE FIGHTING MEASURES

In case of fire where lithium batteries are present, flood area with water or smother with a Class D fire extinguishant appropriate for lithium metal, such as Lith-X. Water may not extinguish burning batteries but will cool the adjacent batteries and control the spread of fire. Burning batteries will burn themselves out. Virtually all fires involving lithium batteries can be controlled by flooding with water. However, the contents of the battery will react with water and form hydrogen gas. In a confined space, hydrogen gas can form an explosive mixture. In this situation, smothering agents are recommended. A smothering agent will extinguish burning lithium batteries.

Emergency Responders should wear self-contained breathing apparatus. Burning lithium manganese dioxide batteries produce toxic and corrosive lithium hydroxide fumes.

SECTION 6 - ACCIDENTAL RELEASE MEASURES

To cleanup leaking batteries:

Ventilation Requirements: Room ventilation may be required in areas where there are open or leaking batteries.

Respiratory Protection: Avoid exposure to electrolyte fumes from open or leaking batteries.

Eye Protection: Wear safety glasses with side shields if handling an open or leaking battery.

Gloves: Use neoprene or natural rubber gloves if handling an open or leaking battery.

Battery materials should be collected in a leak-proof container.

SECTION 7 - HANDLING AND STORAGE

Storage: Store in a cool, well ventilated area. Elevated temperatures can result in shortened battery life. In locations that handle large quantities of lithium batteries, such as warehouses, lithium batteries should be isolated from unnecessary combustibles.

Mechanical Containment: If potting or sealing the battery in an airtight or watertight container is required, consult your Energizer Battery Manufacturing, Inc. representative for precautionary suggestions. Do not obstruct safety release vents on batteries. Encapsulation of batteries will not allow cell venting and can cause high pressure rupture.

Handling: Accidental short circuit for a few seconds will not seriously affect the battery. Prolonged short circuit will cause the battery to lose energy, generate significant heat and can cause the safety release vent to open. Sources of short circuits include jumbled batteries in bulk containers, metal jewelry, metal covered tables or metal belts used for assembly of batteries into devices. Damaging a lithium battery may result in an internal short circuit.

The contents of an open battery, including a vented battery, when exposed to water, may result in a fire and/or explosion. Crushed or damaged batteries may result in a fire.

If soldering or welding to the battery is required, consult your Energizer representative for proper precautions to prevent seal damage or short circuit.

Charging: This battery is manufactured in a charged state. It is not designed for recharging. Recharging can cause battery leakage or, in some cases, high pressure rupture. Inadvertent charging can occur if a battery is installed backwards.

Labeling: If the Energizer label or package warnings are not visible, it is important to provide a package and/or device label stating:

WARNING: Battery can explode or leak and cause burns if installed backwards, disassembled, charged, or exposed to water, fire or high temperature.

Where accidental ingestion of small batteries is possible, the label should include:



(1) KEEP OUT OF REACH OF CHILDREN. Swallowing may lead to serious injury or death in as little as 2 hours due to chemical burns and potential perforation of the esophagus. **Immediately see doctor; have doctor phone (202) 625-3333.** Keep in original package until ready to use. Dispose of used batteries immediately.

SECTION 8 - EXPOSURE CONTROLS/PERSONAL PROTECTION

Ventilation Requirements: Not necessary under normal conditions.

Respiratory Protection: Not necessary under normal conditions.

Eye Protection: Not necessary under normal conditions.

Gloves: Not necessary under normal conditions.

SECTION 9 – PHYSICAL AND CHEMICAL PROPERTIES

Appearance (physical state, color, etc.):	Solid object
Upper Explosive Limits:	Not applicable for an Article
Lower Explosive Limits	Not applicable for an Article
Odor	No odor
Vapor Pressure (mm Hg @ 25°C)	Not applicable for an Article
Odor Threshold	No odor
Vapor Density (Air = 1)	Not applicable for an Article
pH	Not applicable for an Article

Density (g/cm ³)	2.0-3.0
Melting point/Freezing Point	Not applicable for an Article
Solubility in Water (% by weight)	Not applicable for an Article
Boiling Point @ 760 mm Hg (°C)	Not applicable for an Article
Flash Point	Not applicable for an Article
Evaporation Rate (Butyl Acetate = 1)	Not applicable for an Article
Flammability	Not applicable for an Article
Partition Coefficient	Not applicable for an Article
Auto-ignition Temperature	Not applicable for an Article
Decomposition Temperature	Not applicable for an Article
Viscosity	Not applicable for an Article

SECTION 10 – STABILITY AND REACTIVITY

Lithium manganese dioxide batteries contain no sulfides or cyanides and they do not meet any other reactivity criteria including “reacts violently with water” and therefore do not meet any of the criteria established in 40 CFR 261.2 for reactivity.

SECTION 11 – TOXICOLOGICAL INFORMATION

Under normal conditions of use, lithium manganese dioxide batteries are non-toxic.

SECTION 12 – ECOLOGICAL INFORMATION

Issues such as ecotoxicity, persistence and bioaccumulation are not applicable for articles.

SECTION 13 – DISPOSAL CONSIDERATIONS

Lithium iron disulfide batteries are not hazardous waste per the United States Resource Conservation and Recovery Act (RCRA) - 40 CFR Part 261 Subpart C. Dispose of in accordance with all applicable federal, state and local regulations.

SECTION 14 – TRANSPORT INFORMATION

In general, all batteries in all forms of transportation (ground, air, or ocean) must be packaged in a safe and responsible manner. Regulatory concerns from all agencies for safe packaging require that batteries be packaged in a manner that prevents short circuits and be contained in “strong outer packaging” that prevents spillage of contents. All original packaging for Energizer lithium batteries are compliant with these regulatory concerns.

Energizer lithium coin batteries are exempt from the classification as dangerous goods as they meet the requirements of the special provisions listed below. (Essentially, they are properly packaged and labeled, contain less than 1 gram of lithium and pass the tests defined in UN model regulation section 38.3).

Regulatory Body	Special Provisions
ADR	188, 230, 310, 636, 656
IMDG	188, 230, 310, 957
UN	UN 3090, UN 3091
US DOT	29, A54, A100, A101
IATA, ICAO	Packaging Instructions 968 - 970

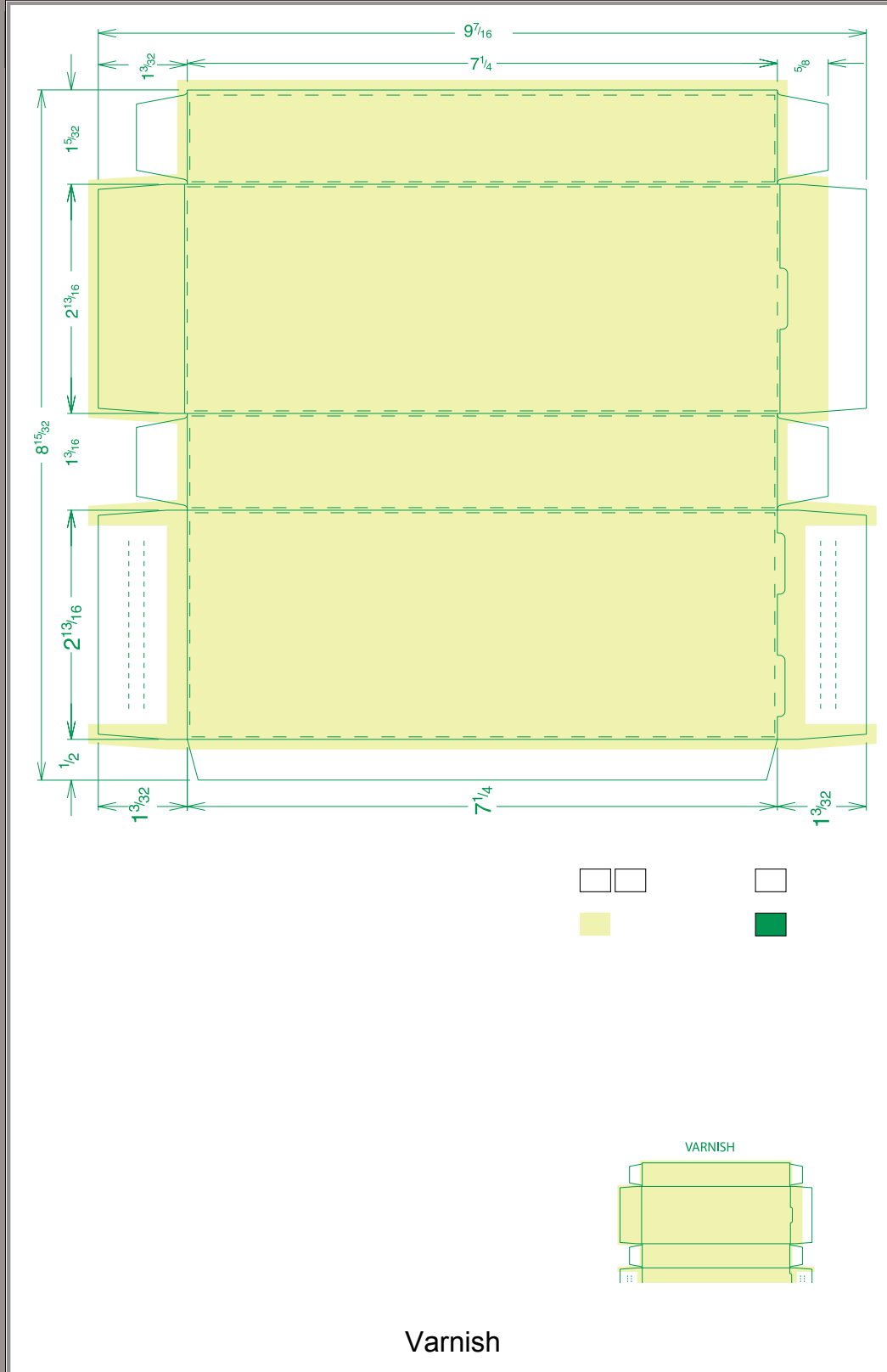

APPROVED
By Miriam Farag at 10:43 am, Nov 24, 2014

 PHOTOTYPE SMARTart GRAVITY + PHOTOTYPE Where art and science meet. 2141 Gilbert Ave., Cincinnati, OH 45206 513.281.0999	MECHANICAL: ROUND 4	
	FRONT COLORS Yellow PANTONE 326 C Magenta PANTONE 225 C Cyan Black Varnish Deline	
JOB INFORMATION JOB DESCRIPTION: First Response Rapid Results 2ct. Pregnancy Test - US BRAND: PWH_FirstResponse FRONT MATERIAL #: notneeded BACK MATERIAL #: notneeded FRONT COPY CODE #: FRFC-90126-11 BACK COPY CODE #: notneeded UPC #: 0 22600 90126 6 LAST REVISION DATE: 11/12/2014		
ADDITIONAL JOB INFORMATION (if available) PRINT PROCESS: Offset PRINTER: Caruastar Carolina Carton, Pineville, NC SUBSTRATE: SBS PRINTER DIE#: CS_CW11188_JOB_01		
C&D APPROVALS ZPK #: 46981 <input type="checkbox"/>		
QUALITY ASSURANCE CHECK LIMITATION OF LIABILITY - DO NOT PLATE OR ENGRAVE WITH THIS FILE OR FILM WITHOUT PROPER INSPECTION All files, film and proofs should be thoroughly inspected by the recipient immediately upon receipt. It is the responsibility of the recipient to examine and proofread all files or film prior to plating or engraving. Should the file(s) or film work be found to be incorrect upon the inspection described above, call 513.281.0999 and ask for the Contact. The liability of Phototype Engraving, Co. Inc. shall be limited to correcting & replacing its own product. Phototype Engraving, Co. Inc. will not be liable for any other loss or damage including, but not limited to, cost of printing plates, cylinders, inks, substrates and/or press time.		

