

广东力科新能源有限公司

Guangdong Pow-Tech New Power Co.,Ltd.

PRODUCT SPECIFICATION

产品规格书

CONFIDENTIAL

Customer: C0914

Model Name: M3 LR2170SD-3S1P

Battery P/N: 5.501.00.00540

Client P/N:

Description: Rechargeable Lithium-ion Battery PACK

Principal/制定	Checked/审核	Approval/批准
梁永胜		
Customer Approval 客户回签		

地址: 深圳市福田区上梅林中康路卓越梅林中心广场南区 A 座 903 室。

ADD: Room903, Tower A,Zhuoyue Meilin central square (South district),Zhongkang Road, Shangmeilin area, Futian District,Shenzhen.

工厂: 东莞市寮步镇横坑石岭工业区横东三路 9 号。

Factory: No.9,Hengdong 3 Road,Hengkeng Shiling industry Zone,liaobuTown,Dongguan.

MODEL	M3 LR2170SD-3S1P	VER	A3	PAGE	3/19
-------	------------------	-----	----	------	------

TABLE OF CONTENTS

目录

1.Application 适用范围	4
2.Battery Pack Overview 电池组概述	4
3.Battery pack outline dimensions 电池组外形尺寸	5
4.Battery pack Specifications 电池组规格	10
5.PCBA Protect Function 保护功能	11
6.Schematic 电路原理图	12
7.PCB Layout PCB 板图	13
8.Key Electronic Components 关键元器件	14
9.Battery Electronic Characteristics 电性能特性	14
10.Reliability Test 可靠性测试	15
11.Packaging 包装	16
12.Handling Precautions and Guideline 操作及注意事项	17
13.Warnings 使用警告	18
14.Warranty period 保质期	18
15.Remarks 备注	18
Appendix A (TBD)	19

MODEL	M3 LR2170SD-3S1P	VER	A3	PAGE	4/19
-------	------------------	-----	----	------	------

1. Application 适用范围

The specification is applicable to Guangdong Pow-Tech New Power Co., Ltd. with basic performance, technical requirement, testing method, warning and caution of the rechargeable Lithium-ion battery.

本规格书规定了可充电锂离子电池的基本性能、技术要求、测试方法及注意事项，本标准只适用于广东力科新能源有限公司。

2. Battery Pack Overview 电池组概述

2.1 Pack Main Characteristics 主要特性

Cell Model 电芯型号	Pack Configuration 电池组配置	Nominal Voltage 标称电压	Nominal Capacity (Typical) 标称容量 (典型)
LR2170SD	3S1P	10.8V	4800mAh

2.2 Connector Terminal Specifications 输出端子规格

Terminal 端子	Name 定义		Description 描述
	PIN6-8	P+	Battery Positive Terminal/ 电池输出正极 UL3302 24#红色
	PIN5	ID	Battery ID/ 电池输出 ID 100K UL3302 24#蓝色
	PIN4	NTC	Battery NTC Terminal/ 电池输出 NTC 10K UL3302 24#白色
	PIN1-3	P-	Battery Negative Terminal/ 电池输出负极 UL3302 24#黑色

Battery pack output port diagram/ 电池组输出端口图

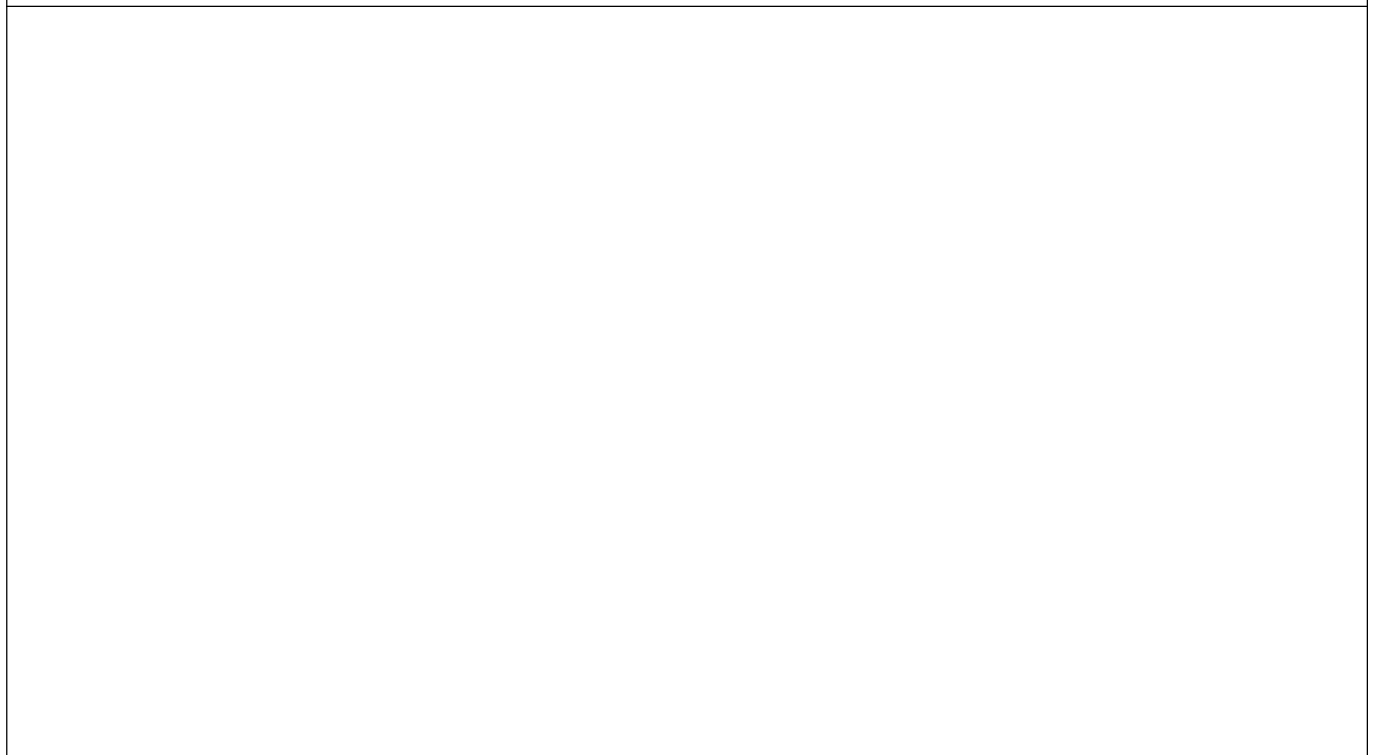

MODEL	M3 LR2170SD-3S1P	VER	A3	PAGE	5/19
-------	------------------	-----	----	------	------

3. Battery pack outline dimensions 电池组外形尺寸

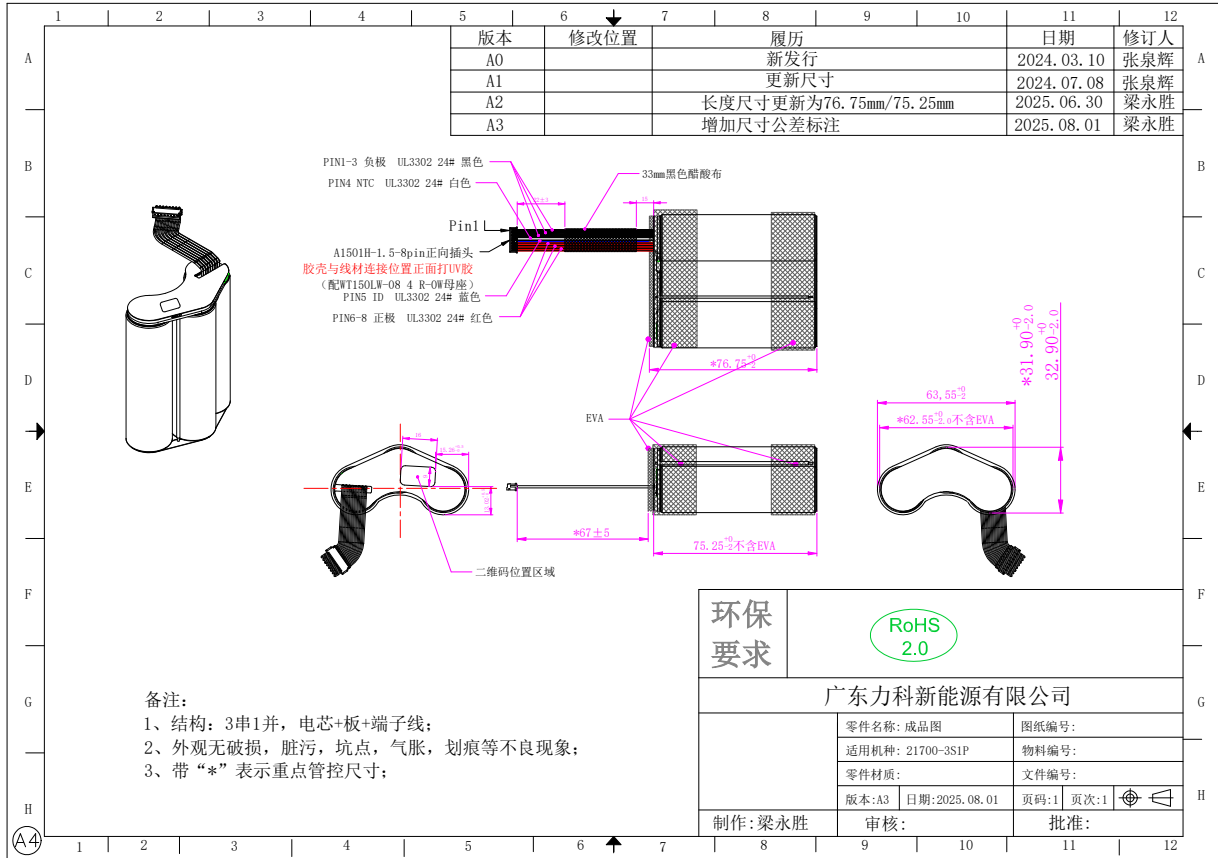

实物照片



MODEL	M3 LR2170SD-3S1P	VER	A3	PAGE	6/19
-------	------------------	-----	----	------	------

二维码

A	<table border="1" style="width: 100%; border-collapse: collapse;"> <tr> <td style="width: 20%;">版本</td> <td style="width: 20%;">更改位置</td> <td style="width: 40%;">履历说明</td> <td style="width: 20%;">日期</td> <td style="width: 10%;">修订人</td> </tr> <tr> <td>A0</td> <td></td> <td>首版发行</td> <td>2024.02.29</td> <td>李昂</td> </tr> </table>				版本	更改位置	履历说明	日期	修订人	A0		首版发行	2024.02.29	李昂	A																		
版本	更改位置	履历说明	日期	修订人																													
A0		首版发行	2024.02.29	李昂																													
B					B																												
C	<h3 style="color: red;">放大图</h3>				C																												
D					D																												
E	<p>二维码说明： 编码格式：QR code(支持手机扫码)； 尺寸：6*6mm±1； 扫码位数34位，包含一切横杠，空格（“ ”表示空格）和字符（明码仅打流水号）； 扫码内容说明：<u>P L 2409 000001 A1 10.80V 4650mAh</u></p> <p> →容量 (固定) →电压 (固定) →生产拉线 (固定) →流水号 (采用十进制，每周归零) →生产周期 (年周) 24年第9周 →电芯供应商 (固定) →公司名称 (固定) </p>				E																												
F	<p>备注： 1、材质：合成纸覆哑膜；胶质：压克力胶；(贴在EVA棉之上) 厚度：0.1mm±0.02mm； 2、阻燃等级：无要求 3、印刷颜色：白底黑字； 4、印字需清晰，不可有重影，断开等不良； 5、需过乙醇、异丙醇、耐磨、剥离测试； 6、带*的为重点管控尺寸，来料方式：片料； 7、标贴周期有效期3个月。</p>				F																												
G	<table border="1" style="width: 100%; border-collapse: collapse;"> <tr> <td style="width: 20%;">环保要求</td> <td style="width: 20%; text-align: center;"> </td> <td colspan="2" style="text-align: center;"> 广东力科新源有限公司 </td> </tr> <tr> <td>未注公差</td> <td>单位: mm</td> <td>零件名称: 二维码标签</td> <td>图纸编号:</td> </tr> <tr> <td>线性尺寸</td> <td>L</td> <td>适用机种: 21700-3S</td> <td>物料编号:</td> </tr> <tr> <td>0≤L≤10</td> <td>±0.1</td> <td>零件材质:</td> <td>文件编号:</td> </tr> <tr> <td>10≤L≤30</td> <td>±0.15</td> <td>版本: A0</td> <td>日期: 2024.02.29</td> </tr> <tr> <td>30≤L≤100</td> <td>±0.2</td> <td>页码: 1</td> <td>页次: 1</td> </tr> <tr> <td>100≤L</td> <td>±0.3</td> <td>制作: 李昂</td> <td>确认: 审核: 批准:</td> </tr> </table>				环保要求		广东力科新源有限公司		未注公差	单位: mm	零件名称: 二维码标签	图纸编号:	线性尺寸	L	适用机种: 21700-3S	物料编号:	0≤L≤10	±0.1	零件材质:	文件编号:	10≤L≤30	±0.15	版本: A0	日期: 2024.02.29	30≤L≤100	±0.2	页码: 1	页次: 1	100≤L	±0.3	制作: 李昂	确认: 审核: 批准:	G
环保要求		广东力科新源有限公司																															
未注公差	单位: mm	零件名称: 二维码标签	图纸编号:																														
线性尺寸	L	适用机种: 21700-3S	物料编号:																														
0≤L≤10	±0.1	零件材质:	文件编号:																														
10≤L≤30	±0.15	版本: A0	日期: 2024.02.29																														
30≤L≤100	±0.2	页码: 1	页次: 1																														
100≤L	±0.3	制作: 李昂	确认: 审核: 批准:																														
H	<table border="1" style="width: 100%; border-collapse: collapse;"> <tr> <td style="width: 20%;">未注公差</td> <td style="width: 20%;">单位: mm</td> <td style="width: 40%;">零件名称: 二维码标签</td> <td style="width: 20%;">图纸编号:</td> </tr> <tr> <td>线性尺寸</td> <td>L</td> <td>适用机种: 21700-3S</td> <td>物料编号:</td> </tr> <tr> <td>0≤L≤10</td> <td>±0.1</td> <td>零件材质:</td> <td>文件编号:</td> </tr> <tr> <td>10≤L≤30</td> <td>±0.15</td> <td>版本: A0</td> <td>日期: 2024.02.29</td> </tr> <tr> <td>30≤L≤100</td> <td>±0.2</td> <td>页码: 1</td> <td>页次: 1</td> </tr> <tr> <td>100≤L</td> <td>±0.3</td> <td>制作: 李昂</td> <td>确认: 审核: 批准:</td> </tr> </table>				未注公差	单位: mm	零件名称: 二维码标签	图纸编号:	线性尺寸	L	适用机种: 21700-3S	物料编号:	0≤L≤10	±0.1	零件材质:	文件编号:	10≤L≤30	±0.15	版本: A0	日期: 2024.02.29	30≤L≤100	±0.2	页码: 1	页次: 1	100≤L	±0.3	制作: 李昂	确认: 审核: 批准:	H				
未注公差	单位: mm	零件名称: 二维码标签	图纸编号:																														
线性尺寸	L	适用机种: 21700-3S	物料编号:																														
0≤L≤10	±0.1	零件材质:	文件编号:																														
10≤L≤30	±0.15	版本: A0	日期: 2024.02.29																														
30≤L≤100	±0.2	页码: 1	页次: 1																														
100≤L	±0.3	制作: 李昂	确认: 审核: 批准:																														
A4	1	2	3	4	5	6	7	8	9	10	11	12																					

PC片增加齿刀压痕线：

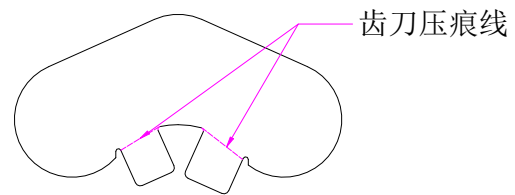
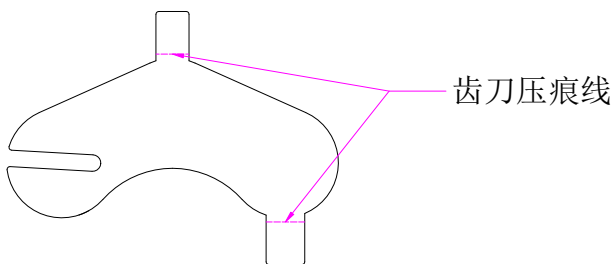



MODEL	M3 LR2170SD-3S1P	VER	A3	PAGE	7/19
-------	------------------	-----	----	------	------

标签:

MODEL	M3 LR2170SD-3S1P	VER	A3	PAGE	9/19
-------	------------------	-----	----	------	------

版本	更改位置	履历说明	日期	修订人
A0		首版发行	2024.02.29	李昂
A1		改为两张标贴，增加新欧规内容，重新排版	2024.06.29	覃焯乾

放大图

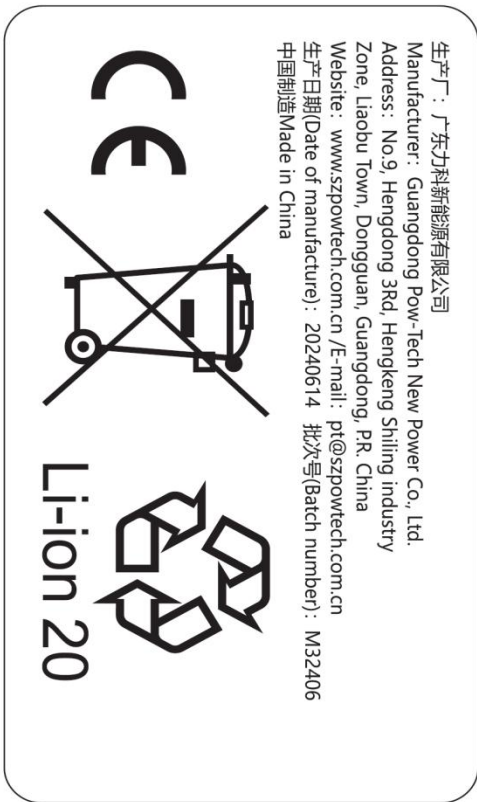
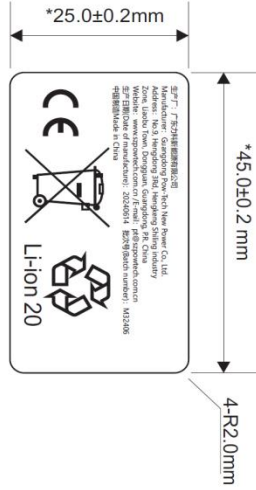

生产日期说明: 20240614(2位)表示2024年6月14日, 按订单要求;
 批次号说明: M3表示固定编码, 2406表示2024年6月, 随月份变化。

备注:

- 1、材质: 合成纸覆哑膜;
- 2、胶质: 压克力胶, 无脱胶, 溢胶;
- 3、厚度: 0.1mm±0.02mm;
- 4、印刷颜色: 白底黑字;
- 5、印刷要求: 文字图案清晰, 无重影, 断开, 斑点, 手印, 边缘不能模糊等不良;
- 6、模切要求: 边缘无毛刺, 无划痕, 无起层, 无偏位;
- 7、其它要求: 需过耐醇、耐磨、剥离测试;
- 8、带*的为重点管控尺寸, 来料方式: 片料;
- 9、标贴周期有效期3个月。

环保要求



广东力科新能源有限公司

未注公差	单位: mm	零件名称: 右标签	图纸编号:
线性尺寸	L	通用机种: C0914-21700-3S1P	物料编号:
0 ≤ L ≤ 10	±0.1	零件材质:	文件编号:
10 ≤ L ≤ 30	±0.15	版本:A1	日期: 2024.06.29
30 ≤ L ≤ 100	±0.2	页码: 1	页次: 1
100 ≤ L	±0.3		

制作: 覃焯乾

确认:

审核:

批准:

MODEL	M3 LR2170SD-3S1P	VER	A3	PAGE	10/19
-------	------------------	-----	----	------	-------

4. Battery pack Specifications 电池组规格

No	Item 项目		Specifications 规格	Remark 备注		
4.1	Capacity 容量	Nominal Capacity (Typical) 标称容量 (典型)	4800mAh	From FC voltage to FD voltage by discharge current 0.2C at 25°C ± 3°C.		
		Rated Capacity (Minimum) 额定容量 (最小)	4650mAh	From FC voltage to FD voltage by discharge current 0.2C at 25°C ± 3°C.		
4.2	Nominal voltage 标称电压		10.8V			
4.3	Charge 充电	Charging Method 充电模式	CC-CV			
		Full Charging(FC) Voltage 最高充电电压	12.6V	Upper limited charge voltage		
		Standard Charging Current 标准充电电流	1440mA			
		Max Charging Current 最大充电电流	3000mA			
		Charging Temperature 充电模式	Temperature		Charge Voltage	Charge Current
			0 to 25°C		4.2V/Cell	1440mA
			25 to 45°C		4.2V/Cell	3000mA
4.4	Discharge 放电	End of Discharging Voltage(FD) 放电截止电压	8.4V	Stop discharge when one cell voltage reach 2.8V @25 ± 3°C.		
		Standard Discharging Current 标准放电电流	930mA			
		Max Discharging Current 最大放电电流	4800mA (连续) 7000mA(不连续放电)			
		Discharge Temperature	Temperature		Discharge Current	
-20 to 10°C			2350mA			

MODEL	M3 LR2170SD-3S1P	VER	A3	PAGE	11/19
-------	------------------	-----	----	------	-------

		放电温度	10 to 55°C	4800mA
4.5	Battery Pack Approx. Weight (g) 电池参考重量		About: 219g±5g	
4.6	Storage Temperature 储存温度	1 year 一年	-20~25°C	If the battery pack (shipping status) store at over the 3 months period, it should be recharged. Humidity: 65±20%
		3 months 三个月	-20~45°C	
		1 month 一个月	-20~55°C	
4.7	AC Impedance 交流内阻		≤ 150mΩ	1KHz AC Method
4.8	As of shipment (status of the delivery) 出货状态 (Pack Voltage 电池组电压)		11.1V-12.0V	
4.9	Cycle Life 循环寿命		>70% after 500 cycles	See 9.2 Electrical Performance For Detail
4.10	ESD static test / 静电测试	Air discharge		± 8KV
		Contact discharge		± 4KV

5. PCBA Protect Function 保护功能

NO	Items	Criteria
5.1	Overcharge Protection Voltage 过充保护电压	4.250 ± 0.025V/Cell
5.2	Over-charge Released Voltage 过充保护恢复电压	4.150 ± 0.050V/Cell
5.3	Over discharge Protection Voltage 过放保护电压	2.800 ± 0.080V/Cell
5.4	Released Voltage from Over-Discharge 过放保护恢复电压	3.000 ± 0.100V/Cell
5.5	Discharge Overcurrent Protection(1st) 放电过流保护(一级)	10.0-14.0A
5.6	Discharge Overcurrent Protection(2nd) 放电过流保护(二级)	42-58A
5.7	charge Overcurrent Protection 充电过流保护	10.0-14.0A
5.8	Over-Charge Protection Delay Time 过充保护延迟时间	1.0s ± 0.5s
5.9	Over-Discharge Protection Delay Time 过放保护延迟时间	1.0s ± 0.5s
5.10	Discharge Over-Current Protection(1st) Delay Time 放电过流保护(一级) 延迟时间	60ms ± 30ms
5.11	Discharge Over-Current Protection(2nd) Delay Time	10 ± 5mS

MODEL	M3 LR2170SD-3S1P	VER	A3	PAGE	12/19
-------	------------------	-----	----	------	-------

	放电过流保护（二级）延迟时间	
5.12	charge Over-Current Protection Delay Time 充电过流保护延迟时间	100ms ± 50ms
5.13	Charge/discharge over-temperature protection delay time 温度保护延迟时间	0.5s-3s
5.14	Short Protection Delay Time 短路保护延迟时间	125u-500us
5.15	Current Consumption(normalmode) 正常状态下静态电流	10uA (max.)
5.16	Current Consumption(sleep mode)休眠状态下静态电流	6uA(max.)
5.17	Resistance Impedance 导通内阻	≤ 60mΩ
5.18	0V Battery Charge Inhibition Voltage 向 0V 电池充电	允许

6. Schematic 电路原理图

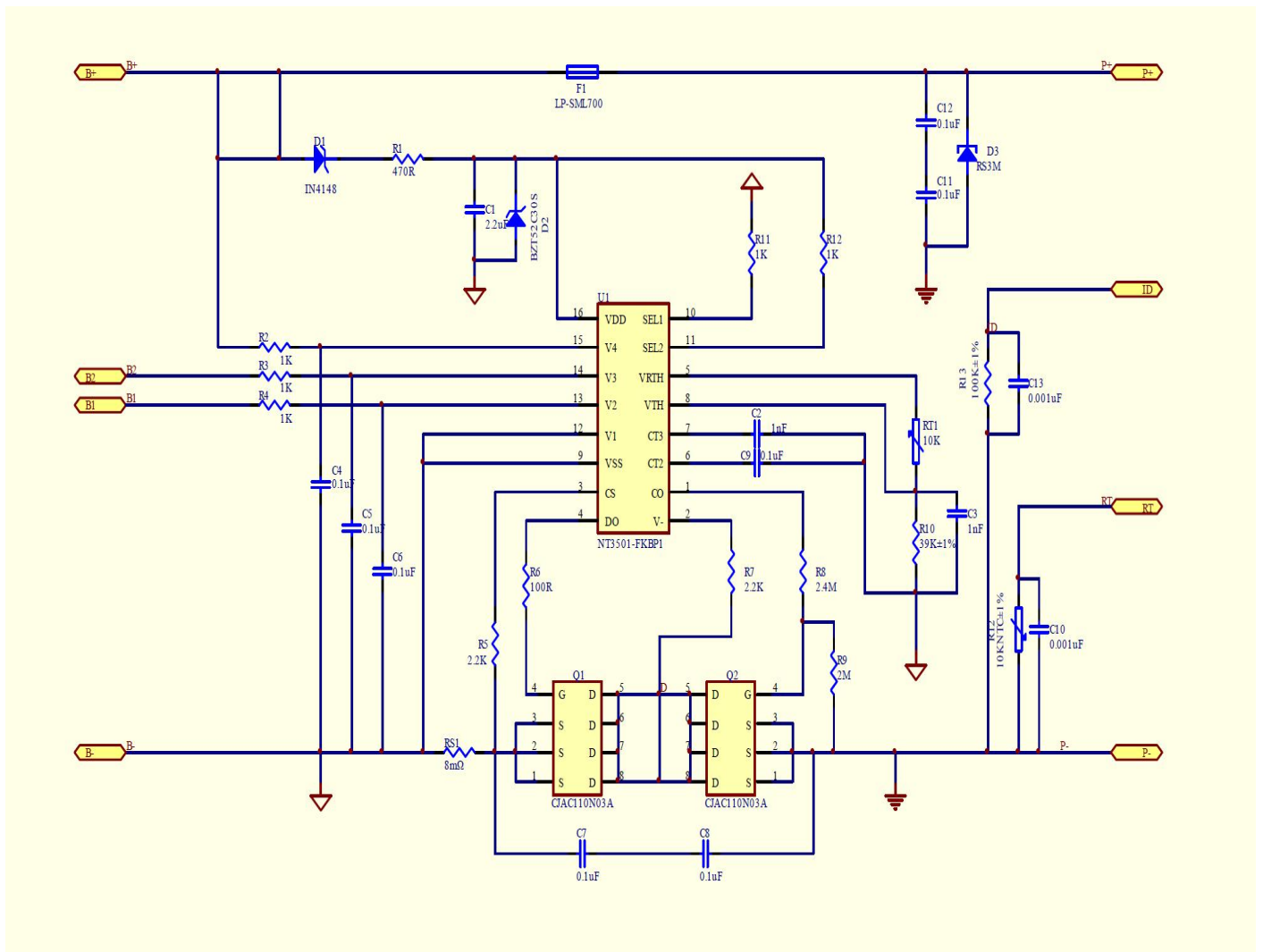

MODEL	M3 LR2170SD-3S1P	VER	A3	PAGE	13/19
-------	------------------	-----	----	------	-------

7. PCB Layout PCB 板图

Top overlay

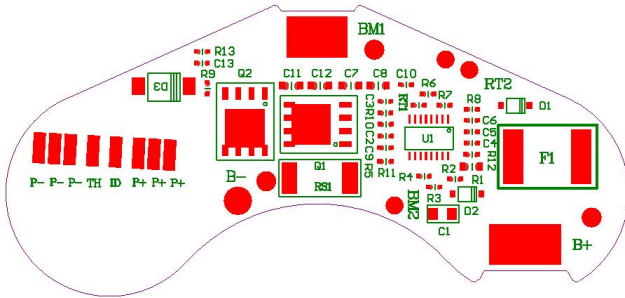

Top Layer

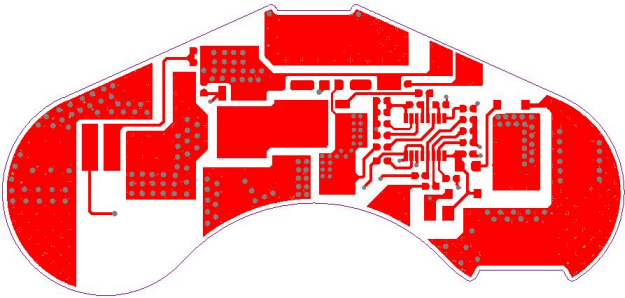

Bottom overlay

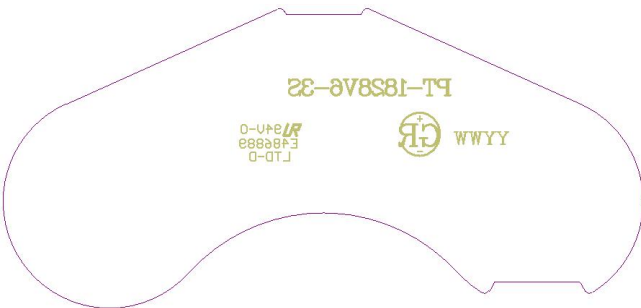

Bottom Layer

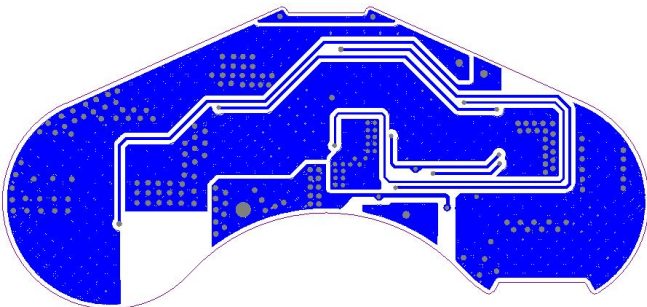

MODEL	M3 LR2170SD-3S1P	VER	A3	PAGE	14/19
-------	------------------	-----	----	------	-------

8. Key Electronic Components 关键元器件

物料代码	物料名称	规格型号/封装形式	单位	数量	品牌
U1	Protection IC	NT3501-FQAP1	PCS	1	新德
Q1, Q2	MOSFET	CJAC110N03A	PCS	2	长电
		LT7404FJ (备选)	PCS	2	领泰
F1	贴片 FUSE	LP-SML700/24	PCS	1	维安
RT2	蝌蚪 NTC	10K Ω , $\pm 1\%$, B=3435, HF, 仙桥	PCS	1	仙桥
R13	ID 电阻	100K 1%	PCS	1	

9. Battery Electronic Characteristics 电性能特性

Standard environmental test condition. Unless otherwise specified, all tests stated in this Product Specification are conducted at below condition:

Temperature : 25°C \pm 3°C, Humidity: 60 \pm 20%

标准环境试验条件。除非另有规定，否则本产品规范中规定的所有试验均在以下条件下进行：温度：25°C \pm 3°C；湿度：60 \pm 20%。

No.	Item/项目	Test Method and Condition/测试方法和条件	Criteria/标准
9.1	Rated Capacity 额定容量	Constant current 1440mA charge to FC Voltage, then constant voltage FC Voltage charge to current declines to 100mA, rest for 10min, constant current 930mA discharge to FD Voltage. 以 1440mA 充电，充电到充电截止电流为 100mA，静置 10 分钟，然后以 930mA 放电到放空电压。	Id=0.2C Capacity \geq 4650mAh
9.2	Cycle Life 循环寿命	Constant current 1440mA charge to FC Voltage, then constant voltage FC Voltage charge to current declines to 0.02C, rest for 10min, constant current 2350mA discharge to FD Voltage, rest for 10min. Repeat above steps till continuously discharge capacity higher than 80% of the initial capacity of the battery. 电池以 1440mA 充电，静置 10 分钟，然后以 2350mA C 放空，静置 10 分钟。重复以上充放电循环直至放电容量低于初始容量的 80%。	Cycle times: \geq 500 times. Capacity \geq 80%. 循环次数：500 次。 容量保持率 \geq 80%。
9.3	Storage Characteristic 荷电保持率	When the battery has completed standard charged, it shall be disconnected and put aside for 28 Days at 25°C \pm 3°C, Then measured the capacity with 0.2 Cmin till FD Voltage. 将充满电后的电池在温度 25 \pm 3°C 环境下存储 28 天，	Retention capacity > 85% 容量保持率 > 85%

MODEL	M3 LR2170SD-3S1P	VER	A3	PAGE	15/19
-------	------------------	-----	----	------	-------

		按照标准的测试容量方法测试剩余容量。	
9.4	Initial Impedance	<p>Using a AC 1KHZ meter whose precision must be less than 0.5%, detect the resistance between the battery' s positive and negative terminals. The result value can not include any external conductor' s resistance. The maximum and the minimum need to be recorded.</p> <p>使用AC 1KHz 检测方法及准确度不低于0.5 级的仪表, 测量电池接口处正负极之间的内阻值, 若检测仪表在检测过程中使用附加的电池固定夹具和引线, 可以视情况减去固定引线的电阻值, 且记录最大与最小之差值。</p>	The internal resistance $\leq 150\text{m}\Omega$ 电池内阻值小于或等于 150m Ω 。
9.5	ESD Test	<p>Method: 5 times/pin , Frequency: 1min/time Non-operating: Contact: $\pm 4\text{KV}$;Air: $\pm 8\text{KV}$</p> <p>对电池组每个端子或者电路板的输出端子进行 $\pm 4\text{KV}$ 接触放电测试各 5 次和 $\pm 8\text{KV}$ 空气放电测试各 5 次, 每两次放电测试时间间隔 1 分钟。</p>	<p>No explosion and no fire. Its protection function shall not fail. if it is equipped with protection circuit.</p> <p>电池组应不起火、不爆炸, 如有保护电路其保护功能不应失效。</p>

10. Reliability Test 可靠性测试

No.	Item/项目	Test Method and Condition/测试方法和条件	Criteria/标准
10.1	Over-Voltage Charge Test 过压充电测试	<p>After standard charging, the battery is conducted for 8 hours while the constant voltage is held at 4.6V/cell and standard charging current flows through it.</p> <p>将标准充电后的电芯, 用恒定电压 4.6V/ 串和标准充电电流给电池进行加压 8h.</p>	No explosion, No fire 无爆炸、无起火
10.2	Short-circuit Test 外部短路测试	<p>Rest battery for 30min at $20 \pm 5^\circ\text{C}$ after standard charged. Connect between battery terminals with copper lead (electric resistance: $80\text{ m}\Omega \pm 20\text{m}\Omega$) and leave for 12hour.</p> <p>将电池组充满电后, 短路电池组的正负极端子, 外部短路总电阻为 $80\text{ m}\Omega \pm 20\text{m}\Omega$。保持电池组短路 12h.</p>	<p>No explosion, No fire. Max. Temp of Battery surface should not exceed 150°C.</p> <p>无爆炸、无起火, 电池组表面温度不超过 150°C.</p>
10.3	Heating Test 热冲击	<p>The battery is placed in a thermal chamber. Temperature is raised to $130 \pm 2^\circ\text{C}$ at the rate of $(5 \pm 2^\circ\text{C})/\text{min}$ and held for 10 minutes, then cooled to room temperature at the rate of $5 \pm 2^\circ\text{C}/\text{min}$.</p> <p>电池置于热箱中, 温度以 $(5 \pm 2^\circ\text{C})/\text{min}$ 的速率升至 $130 \pm 2^\circ\text{C}$ 并保温 10min, 再以 $5 \pm 2^\circ\text{C}/\text{min}$ 的速度降至室温.</p>	No explosion, No fire. 无爆炸、无起火。

MODEL	M3 LR2170SD-3S1P	VER	A3	PAGE	16/19
10.4	Temperature cycling Test 温度循环测试	<p>T The batteries are to be placed in a test chamber and subjected to the following cycles:</p> <p>A: Raising the chamber temperature to $70 \pm 3^\circ\text{C}$ within 30 minutes and maintaining this temperature for 4 hours.</p> <p>B: Reducing the chamber temperature to $20 \pm 3^\circ\text{C}$ within 30 minutes and maintaining this temperature for 2 hours.</p> <p>C: Reducing the chamber temperature to minus $40 \pm 3^\circ\text{C}$ within 30 minutes and maintaining this temperature for 4 hours.</p> <p>D: Raising the chamber temperature to $20 \pm 3^\circ\text{C}$ within 30 minutes and maintaining this temperature for 2 hours.</p> <p>E: Repeating the sequence for a further 10 cycles.</p> <p>电池应放置在测试温柜中，并进行下列循环：</p> <p>A: 30 分钟内将温柜温度提高到 $70 \pm 3^\circ\text{C}$，维持 4 小时。</p> <p>B: 30 分钟内将温柜温度降至 $20 \pm 3^\circ\text{C}$，维持 2 小时。</p> <p>C: 30 分钟内将温柜温度降至 $-40 \pm 3^\circ\text{C}$，维持 4 小时。</p> <p>D: 30 分钟内将温柜温度提高到 $20 \pm 3^\circ\text{C}$，维持 2 小时。</p> <p>E: 重复这个测试 10 个周期。</p>			No explosion, No fire 无爆炸、无起火。
10.5	Vibration Test 振动测试	<p>After standard charging, the battery is secured to a vibration table and subjected to vibration cycling in which the frequency is varied at the rate of 1Hz per minute between 10Hz and 55Hz; the excursion of the vibration is 0.8mm. The battery shall be vibrated for 100 minutes on each of X, Y, and Z axis.</p> <p>将标准充电后的电池固定在振动台上，并沿 X、Y、Z 三个方向各振动 100 分钟，振幅为 0.8mm，振动频率为 10Hz—55Hz，每分钟变化 1Hz。</p>			No explosion, No fire. 无爆炸、无起火。
		<p>Remark: The test is not suitable for battery pack with no housing. 备注：本试验不适用于无壳电池组。</p>			
10.6	Drop Test 跌落测试	<p>After full charged, the battery is dropped from a height of 1 meter three times onto a concrete surface.</p> <p>电池组是满电状态，然后从 1 米的高度跌落 3 次到混泥土板上。</p>			No explosion, No fire 无爆炸、无起火。
		<p>Remark: The test is not suitable for battery pack with no housing. 备注：本试验不适用于无壳电池组。</p>			

11. Packaging 包装

The sketch, sizes, color of marking should match GB/T191-2016 requests.

标志的图形、尺寸、颜色应符合 GB/T 191—2016 的要求。

The manner of packing should match 2019 IATA DGR 60th Edition requests.

包装方式符合 2019 IATA DGR 60 的要求。

12. Handling Precautions and Guideline 操作及注意事项

12.1 Charge 充电

Charge current: Never out of the max charge current as mentioned in specification.

充电电流：不能超过规格书规定的最大的充电电流。

Charge voltage: Never out of the max charge voltage as mentioned in specification.

充电电压：不能超过规格书规定的最高的限制电压。

Charge temperature: Please refer to the temperature range as specification.

充电温度：电池充电温度必须按照规格书的温度范围执行。

Charge as constant current before constant voltage, Never reverse the charge mode.

先恒流后恒压方式充电，禁止颠倒的方式充电。如果电池正负极颠倒充电会带来危险。

12.2 Discharge current 放电电流

The discharge current is not allowed to out of max current as specification. Otherwise, the battery will be over heat and capacity fading.

电池放电电流不能超过规格书规定的最大放电电流，过大的电流放电会造成电池发热和容量衰减。

12.3 Discharge temperature 放电温度

Please refer to the temperature range as specification.

电池放电温度必须按照规格书的温度范围执行。

12.4 Over-discharge 过放电

It's workable if over charge and discharge for a short while but not allow to do it for a long time. Over discharge may result in disappear self-energy. Please keep a certain electric quantity to prevent over discharge.

短时间的过充过放不影响电池的使用，但是长时间的过放电会影响到电池的功能失效，电池永久性不能适用，电池可能过放还有一个原因是自动能量的消失。预防电池过放的出现方法是电池应保持一定的电量。

12.5 Storing the Batteries 贮存电池

Please store the battery in the adequate temperature as mentioned in specification. When battery is delivered, if the capacity is about 60%. Suggest to recharge it after more than 6 months. When battery is charged full, Suggest to recharge it after more than 9 mouths.

电池贮存在规格书规定的温度范围内。如果电池出货时带电量在60%左右，建议贮存超过六个月时，给电池充电；电池充满电后贮存时，建议贮存超过九个月时，给电池充电。

12.6 Storage 贮存

- Store the battery in cool, dry and well-ventilated conditions.

电池贮藏在通风干燥的环境中。

- Regulations vary for different countries. Dispose of in accordance with local regulations.

不同国家法规的不同，处理时根据当地的法规。

12.7 Other Chemical Reaction 其它化学反应

The battery performance will reduce if over time using or unused for a long time due to It's a reaction of chemical. In addition, the battery life will be shorten or injury or damage itself from electrolyte leakage, heating ignition or explosion for improper handling. It's necessary to replace battery if unable to charge for a long time even with proper way.

由于电池是利用化学反应的原理，所以随着时间的增加电池的性能会降低，即使是存放很长一段时间而不使用。如果使用条件如充电、放电及周围环境温度等情形不在指定的使用范围内，也会缩短电池的使用寿命，或者产生漏液导致电池损坏。如果电池长周期不能充电，即使充电方法正确，这样需要更换电池。

13. Warnings 使用警告

Please read the manual carefully before using it to ensure properly use.

为了使电池安全的使用及处理请在使用前认真的阅读操作说明。

- Do not make the battery exposure or thrown into fire.
不能把电池曝晒或丢在火中.
- Never reverse charge the battery.
电池充电时不能把正负极性装反.
- Never short circuit the battery.
避免短路电池.
- Avoid excessive physical shock or vibration.
避免过分的物理震动和冲击电池.
- Do not disassemble or deform the battery.
不能拆解或使电池变形.
- Never allow the battery to get wet or be immersed in water.
不能将电池浸入水中.
- Do not use different types of battery together.
不能将其它不同厂家、类型、型号的电池混合使用.
- Keep away from children.
禁止小孩接触电池.
- Charge at the appropriate conditions.
电池必须在合适的条件下充电.
- Never use the faulty charger to charging.
决不能用故障的充电器给电池充电.
- Never keep charging more than 24 hours.
电池持续充电不能超过 24H.

14. Warranty period 保质期

Guarantee period of quality is one year from the date of shipment. Pow-Tech guarantees to give a replacement in case of battery with defects proven due to manufacturing process instead of the customer's abuse.

电池的保质期从出货之日算起为一年。如果证明电池的缺陷是在 Pow-Tech 公司制造过程中造成的而不是客户错误使用造成，本公司负责退换电池。

15. Remarks 备注

15.1 What has been mentioned above can be regarded as the conventional framework between the supplying and requisitioning parties in respect to the product performance and examination rule of the battery.

上述内容可以作为供需双方对于电池产品性能和检验规则的约定框架。

15.2 Use of the information described herein for other purposes and/or reproduction or copying without the express permission of POW-TECH is strictly prohibited.

本资料内容未经本公司许可，严禁以其他目的加以转载或复制等。

15.3 No responsibility is assumed by us for any consequence resulting from any wrong or improper

MODEL	M3 LR2170SD-3S1P	VER	A3	PAGE	19/19
-------	------------------	-----	----	------	-------

use of operation, etc. of the product.

如因误操作或者不正当使用等造成的相关后果，我司不负任何责任。

15.4 Any other items which are not covered in this specification shall be agreed by both parties.

本规格书未包括事项应由双方协议确定。

Appendix A (TBD)