



## 成品规格确认书

### Specification for Approval

<b>Series</b> 产品系列	Lithium Polymer
<b>Model and Capacity</b> 型号及容量	803450-1500
<b>Customer Name or code</b> 客户名称或代码	
<b>File No.</b> 文件编号	YXE-SPC-CP-P 1329
<b>File Version</b> 版本号	A0
<b>Issue Date</b> 发行日期	2021-10-11

<b>批准</b> Approved  翟英杰	<b>审核</b> Checkup  曾祥建	<b>制作</b> Prepared  张光勇
----------------------------------	---------------------------------	----------------------------------

<b>Customer Approval</b> 客户确认	<b>Signature</b> 签名	<b>Date</b> 日期
	<b>Company Name:</b> 公司名称:	
	<b>Company Stamp:</b> 公司印章:	





## Contents

### 目录

1. 适用范围	
Scope .....	3
2. 体系	
System .....	3
3. 常规技术参数	
General Specifications .....	3
4. 产品性能测试	
Product performance test .....	4
5. 产品贮存及运输	
Product Storage and Transportation .....	6
6. 电池操作指引及注意事项	
Battery Handling Guideline .....	7
7. 备注	
Remark .....	8
8. 附录	
Appendix .....	9



## 1. 适用范围

### Scope

本产品规格书适用于东莞市煜信恩能源科技有限公司向客户提供的可充电锂聚合物电池产品 YXE 803450。

This specification is applied to Li-ion Battery YXE 803450 produced by DONG GUAN YU XIN EN ENERGY TECHNOLOGY CO.,LTD.

## 2. 体系

### System

可充电聚合物锂离子电池

Li-ion Battery

## 3. 常规技术参数

### General Specifications

NO.	项目 Item	规格参数 Specification
1	型号 Model	YXE 803450
2	额定容量 Rated Capacity (@1500mA)	最小值: Min.: 1480mah (@300mA charge and 300mA discharge)
		特征值: Typical: 1500mah (@300mA charge and 300mA discharge)
3	内阻 internal Impedance	≤ 140mohm
4	标称电压 Nominal Voltage	3.7V
5	充电截止电压 Charging Voltage	4.2V
6	充电方法 Charging Method	恒流恒压充电 CC&CV
	标准充电制度 Standard Charging Process	在 25°C±5 °C 下, 以 300mA 恒流充电至 4.2V, 然后恒压充电到充电电流减小到 15mA, 即充满电。 300mA(CC) charge to 4.2V, when 4.2V (CV) is reached, charge rate will reduce to 15(mA )for full charge
7	放电方法 Discharging Method	恒流放电 constant current discharge
8	标准放电制度 Standard Discharge method	在 25°C ±5 °C 下以 300mA 恒流放电至 3.0V。 Cells should be discharged at a constant current of 300mA to 3.0 volts at 25°C ±5 °C



9	标准放电时间 Standard discharge time	≥300min	
10	最大充电电流 Maximum charging current	750mA	
11	最大持续放电电流 Max. Continuous Discharge Current	1500mA	
12	最大放电电流 maximum discharge current	1500mA	
13	放电截止电压 Discharge Cut-Off Voltage	3.0V	
14	电池重量(最大值) Battery Weight(MAX)	29.0g	
15	电池循环寿命 (标准充放电) battery Cycle Life (standard charge & discharge)	≥ 300 次 (注:剩余容量≥80% remark: the residual capacity is more than 80% of the first cycle discharge capacity)	
16	操作温度 Operating Temperature	放电 Discharge	
17	贮存温度 Storage temperature	充电 Charge	10°C to 45°C
		贮存 Storage	0°C to 45°C
		1 个月内 Within 1 month	10°C to 35°C
		3 个月内 Within 3 month	- 5°C ~ +40°C
		6 个月内 Within 6 month	- 5°C ~ +35°C

#### 4. 产品性能测试

##### Products performance test

NO.	Items	Test condition and method	Criterion
1	荷电性能 Self-discharge Performance	标准充电后在 20±5°C 条件下贮存 30 天, 然后用 0.2C 的电流放电至放电截止电压 Standard Charged, lay for 30 days in the ambient temperature of 20 °C±5 °C, then discharge to the discharge end voltage 3.0 V at the current of 0.2C	放电容量: ≥85%初始容量 The discharge Capacity: should not less than 85% of Initial Capacity
2	高温放电性能 High Temperature Discharge	标准充电后, 把电池放入 65±5°C 高温箱中搁置 2 小时, 然后用 0.2C 的电流放电至放电截止电压 Standard Charged, lay for 2 hours in the ambient temperature of 65°C±5 °C, then discharge to the	放电容量 ≥ 90%常温放电容量 The Discharge capacity should not less than 90%



		discharge end voltage 3.0V at the current of 0.2C	of the capacity that discharge at normal temperature
3	低温放电性能 Low Temperature Discharge	标准充电后，把电池放入-10±5℃低温箱搁置 4-6h 后用 0.2C 的电流放电至放电截止电压 Standard Charged, lay for 4-6 hours in the ambient temperature of -10 °C±5 °C ,then discharge to the discharge end voltage 3.0V at the current of 0.2C	放电容量 ≥ 50%常温放电容量 The Discharge capacity should not less than 50% of the capacity that discharge at normal temperature
4	过充电测试 Over charge test	标准充电后，恒流恒压源设定为 5.0V 以 1C 的电流持续充电 8h Battery charged at 1.0C current with a voltage limit of 5.00V.charging is continued for 8 hours.	不爆炸、不起火 no explosion, no fire
5	过放测试 Over-discharge	0.5C 放电至 3.0V 后再以 0.2C 的电流放电至 0V Battery discharged continuously at the constant current of 0.5C to 3.0V,then discharge the battery with a current of 0.2Cto 0V	不爆炸、不起火 No Explosion, No Fire
6	热冲击测试 Heating Test	将满电电池置于高温箱中、温度以 (5±2) °C/min 升到 130±2℃并保温 30 分钟 The temperature of the oven is to be raised at a rate of 5±2°C/min. to a temperature of 130±2°C, and remains for 30 minutes at this temperature.	不爆炸、不起火 No Explosion, No Fire
7	振动测试 Vibration test	电池在振幅为 0.8 mm (1.6mm) 的简谐振动，振动频率为：10~55 Hz,扫频速率为:1 Hz/min, X、Y、Z 三个方向各振动一次，振动时间为 30min. Let the battery subjected simple harmonic motion with an amplitude of 0.8 mm (1.6mm ) total maximum excursion].The frequency is to be varied at the rate of 1 hertz per minute between 10 and 55 hertz, The battery is to be tested for 30 min in each mutually perpendicular directions.	不爆炸、不起火 No Explosion, No Fire
8	自由跌落测试 Free falling(drop) Test	标准充电后，搁置 2 小时,从 1m 高处自由跌落到 30mm 厚的木板上,各方向一次。 Fully charge, lay for 2 hours , drop the battery from a height of 1m to a wooden board with the thickness of 30mm. Each side for one time.	不爆炸、不起火 (ΔV<0.20V/Set ΔR<5%/Set) No Explosion, No Fire
9	外部短路测试 External Short-circuiting test	标准充电后，使用总内阻不大于 100mΩ的导线短路正负极，当电池温度下降到比峰值低约 10 °C 时，结束试验。 Fully charge, Short circuit by connecting the positive and negative terminals with a circuit load having a maximum resistance load of 100mΩ ,until its temperature has fallen by 10 °C from the peak point ,the test is over .	不爆炸，不起火 No explosion, no fire
10	温度循环测试 Temperature Cycling Test	70±3℃条件下搁置 4 小时；在 20±3℃条件下搁置 2 小时；在-40±3℃条件下搁置 4 小时；在 20±3℃条件下搁置 2 小时；按以上的步骤循环 10 次，并且每次温度变换时间不得超过 30min 。 70 ±3°C maintaining for 4 hours.20±3°C	不着火、不爆炸；不漏气、不漏液 No Explosion, No Fire and Not vent or leak



		maintaining for 2 hours.-40 ±3°C maintaining this temperature for 4 hours.20±3°C for 2 hours. Repeating the sequence for a further 9 cycles. And the temperature change should be finished within 30 min	
11	恒定湿热测试 Humidity and heat test	将标准充电后的电芯放入温度为40°C±2°C，相对湿度为90%~95%的恒温恒湿箱中48h A charged battery is placed in a box for 48 hours where the temperature is 40°C±2°C and the relative humidity is 90%~95%	无冒烟、爆炸 No smoke or explosion
12	重物冲击测试 Impact test	电池充满电后，把电池放在一个平面上，将直径为15.8mm的钢棒放到电池的中心，用重量为9.1kg的重物从610mm的高度跌落到电池上。 After full charged,place the battery on a flat surface. A 15.8mm diameter bar is to be placed across the center of the sample. A 9.1 kg weight is to be dropped from a height of 610±25 mm onto the sample.	不爆炸，不起火 No explosion, no fire
13	挤压测试 Crush Test	在两个平面间对电池进行挤压，压力通过直径为32mm的活塞提供，压强为17.2 MPa，压力为13 kN即可停止。 Crush the battery between two flat surfaces ,The force for the crushing is to be applied by a hydraulic ram with a 32 mm diameter piston. The crushing is to be continued until a pressure reading 17.2 MPa is reached on the hydraulic ram, applied force of 13 kN.	不爆炸，不起火 No explosion, no fire

## 5. 产品贮存及运输

### Product Storage and Transportation

#### 5.1 产品贮存

##### Product Storage

如电池贮存3个月以上，电池须置于温度为20±5°C、湿度为65±20%RH的环境中，电池的贮存电压需保持在3.8V~4.0V，请每隔3个月激活电池一次，具体方法如下:标准充放电后，搁置5分钟，750mA充电至4.0V

If the cell is to be stored for 3 months or longer , the environment should be as follows:

Temperature: 20±5°C Humidity: 65±20%RH

Voltage during storage needs to be maintained between 3.8V~4.0V .

Please charge & discharge the battery once every 3 months according to the following method:

Standard charge/discharge, lay for 5 min, then charge at 750mA to 4.0V.

#### 5.2 产品运输

##### Product Transportation



电池在运输中为半电状态，应避免剧烈震动、挤压、日晒及浸湿。

During transportation the battery is approximately at a state of 50% charged, the battery should avoid from acute vibration, crushed, solarization, soaked.

## 6. 电池操作指引及注意事项

### Handling Precautions and Guideline

声明一：

客户若需要将电池用于超出文件规定以外的设备，或在文件规定以外的使用条件下使用电池，应事先联系煜信恩，因为需要进行特定的实验测试以核实电池在该使用条件下的性能及安全性。

Note(1):

If the battery is used to other equipments , or used condition is not accord to the condition in this Specification they should contact With YU XIN EN in advance, Additional experimentation may be required to verify the performance and safety under the conditions.

声明二：

对于在超出文件规定以外的条件下使用电池而造成的任何意外事故煜信恩概不负责

Note(2):

YU XIN EN will take no responsibility for any accident when the battery is used under other conditions beyond those described in this Document.

声明三：

如有必要，煜信恩会以书面形式告之客户有关正确操作使用电池的改进措施。

Note(3):

YU XIN EN will inform the customer of improvements regarding proper use and handing of the battery in a written form, if it is necessary.

#### 6.1. 充电 Charging

电池必须在 10℃~45℃ 的环境温度范围内进行充电，充电电流不得超过本标准书中规定的最大充电电流。充电电压不得超过本标准书中规定的额定电压,4.2V 为充电电压最高极限，充电器的设计应满足此条件；禁止反向充电，

The battery should be charged within 10℃~45℃ specified in this Specification. The battery should be charged at a current less than the maximum charge current specified in this Specification.

Charging Voltage should be less than the specified in this Specification. The Max Charging Voltage is 4.2V, and the charger should be designed to meet with this requirement. Prohibiting to reverse charge.

#### 6.2. 放电 Discharging

电池必须在 -10℃~50℃ 的环境温度范围内进行放电，放电电流不得超过本标准书规定的最大放电能



流，注意在电池长期未使用期间可能会因其它自放电特性而处于某种放电状态。为防止电池过放电，应定期充电，保持其电压高于 3.0V。

The battery should be discharged within  $-10^{\circ}\text{C} \sim 50^{\circ}\text{C}$  specified in this Specification, The battery should be discharged at a current less than the maximum discharge current specified in this Specification. Notice that the battery would be at force-discharged state by its self-discharge characteristics in case the battery is not used for long time. In order to prevent over-discharging, the battery shall be charged periodically to maintain above 3.0V.

### 6.3. 其它事项 Others

6.3.1. 防止电池内短路 Prevent internal short circuit

6.3.2. 严禁拆卸电池 Prohibit disassembly

6.3.3. 在任何情况下，不得将电池投入火中，否则会引起电池燃烧。

Never dispose the battery in fire. It may cause the battery firing.

6.3.4 不得将电池浸泡于液体中，如淡水、海水、饮料等

The battery should never be soaked in liquids such as freshwater, seawater and drinks.

6.3.5. 禁止使用已损坏的电池 Prohibit to use damaged battery

## 7. 备注

### Remarks

若发现此规格书有任何问题，需经双方同意后方可修改。

If any matters concerning the specifications of the battery, it must be mutually agreed before any revision of the specifications are made.

## 8. 附录

### Appendix

#### 8.1 产品线路图

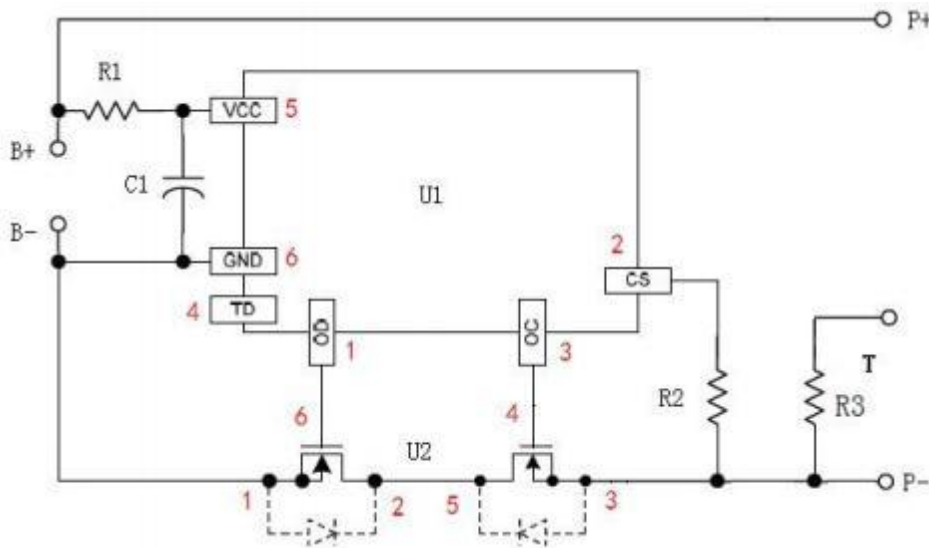

#### 8.2 保护板外观:

顶层元件面:

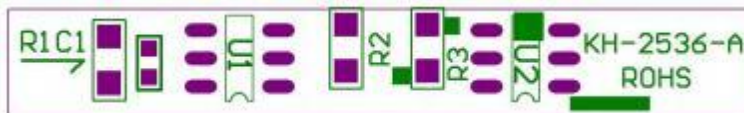

顶层线路:



背面元件面:



背面线路:

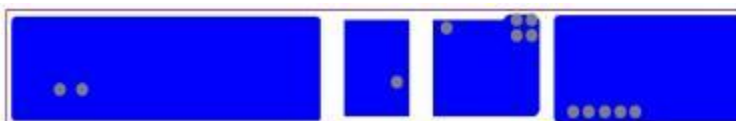



8.3 技术参数 (参照相应元器件技术规格书, 在常温 25℃下测试, 相对湿度≤90%)

检测项目	Min	Typ	Max	Unit
输入电压(B+与 B-间)	1.5		8	V
过充保护电压	4.23	4.28	4.33	V
过充释放电压	4.03	4.08	4.13	V
过充保护延迟时间		120	160	ms
过放保护电压	2.3	2.4	2.5	V
过放释放电压	2.9	3.0	3.1	V
过放保护延迟时间		60	80	ms
充电过流保护	-	-	-	A
放电过流保护	2.5	3.5	5.0	A
过流保护延迟时间	5	7	12	ms
静态电流	1.0	3.5	6	uA
保护板内阻		45	65	mΩ
短路保护	有, 断开负载或充电自恢复			
短路保护延迟时间		400	600	us
最大工作温度范围	-40		+80	°C

#### 8.4 产品尺寸图

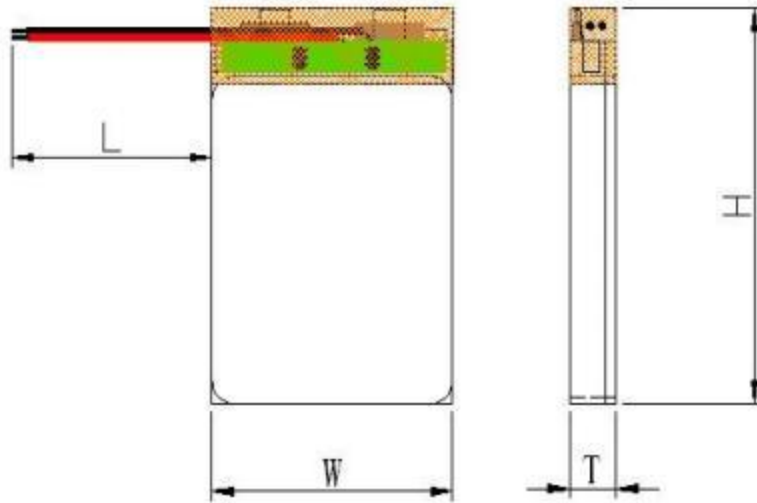

测量项目	基准值: mm	公差: mm	元器件	规格	种类
H : 产品总高度	52	±2.0	保护板	KH-2536	DW01+8205-6
T : 电芯厚度	8.0	+0.2/-0.5	线材	24#	1571
W : 电芯宽度	34	±0.5			
L : 线材外露长	40	±3.0			
W1: 剥线长	50	±0.5			
线总长	R=69 B=72	±3.0			